

# **Advances in the Modular Multiscale Microphyscs and Transport Package for Alaro-0**

Luc Gerard

8 April 2008



# Advances in 3MT

1. General comments
2. The updraught in 3MT
3. Updraught closure in 3MT
4. Cascade and closure
5. Entraining ascent segment
6. Detrainment area
7. Convective fractions
8. Numerical consistency
9. Recent results : Heavy thunderstorms — Downpours — Thin squall lines
10. Further work

# Peaceful Ideals for Alaro-0/3MT

# Peaceful Ideals for Alaro-0/3MT

- Promoting collaboration between concurrent ideas and facilitating test of new concepts

(modularity)

# Peaceful Ideals for Alaro-0/3MT

- Promoting collaboration between concurrent ideas and facilitating test of new concepts  
(modularity)
- Releasing assumptions conflicting with high resolutions  
(prognostic approaches, refined parametrizations)

# Peaceful Ideals for Alaro-0/3MT

- Promoting collaboration between concurrent ideas and facilitating test of new concepts  
(modularity)
- Releasing assumptions conflicting with high resolutions  
(prognostic approaches, refined parametrizations)
- Clearing conflicts between concurrent schemes

# Peaceful Ideals for Alaro-0/3MT

- Promoting collaboration between concurrent ideas and facilitating test of new concepts  
(modularity)
- Releasing assumptions conflicting with high resolutions  
(prognostic approaches, refined parametrizations)
- Clearing conflicts between concurrent schemes

subgrid → · ← resolved

# Peaceful Ideals for Alaro-0/3MT

- Promoting collaboration between concurrent ideas and facilitating test of new concepts  
(modularity)
- Releasing assumptions conflicting with high resolutions  
(prognostic approaches, refined parametrizations)
- Clearing conflicts between concurrent schemes

subgrid → · ← resolved



convective ≠ stratiform



# Updraught in 3MT

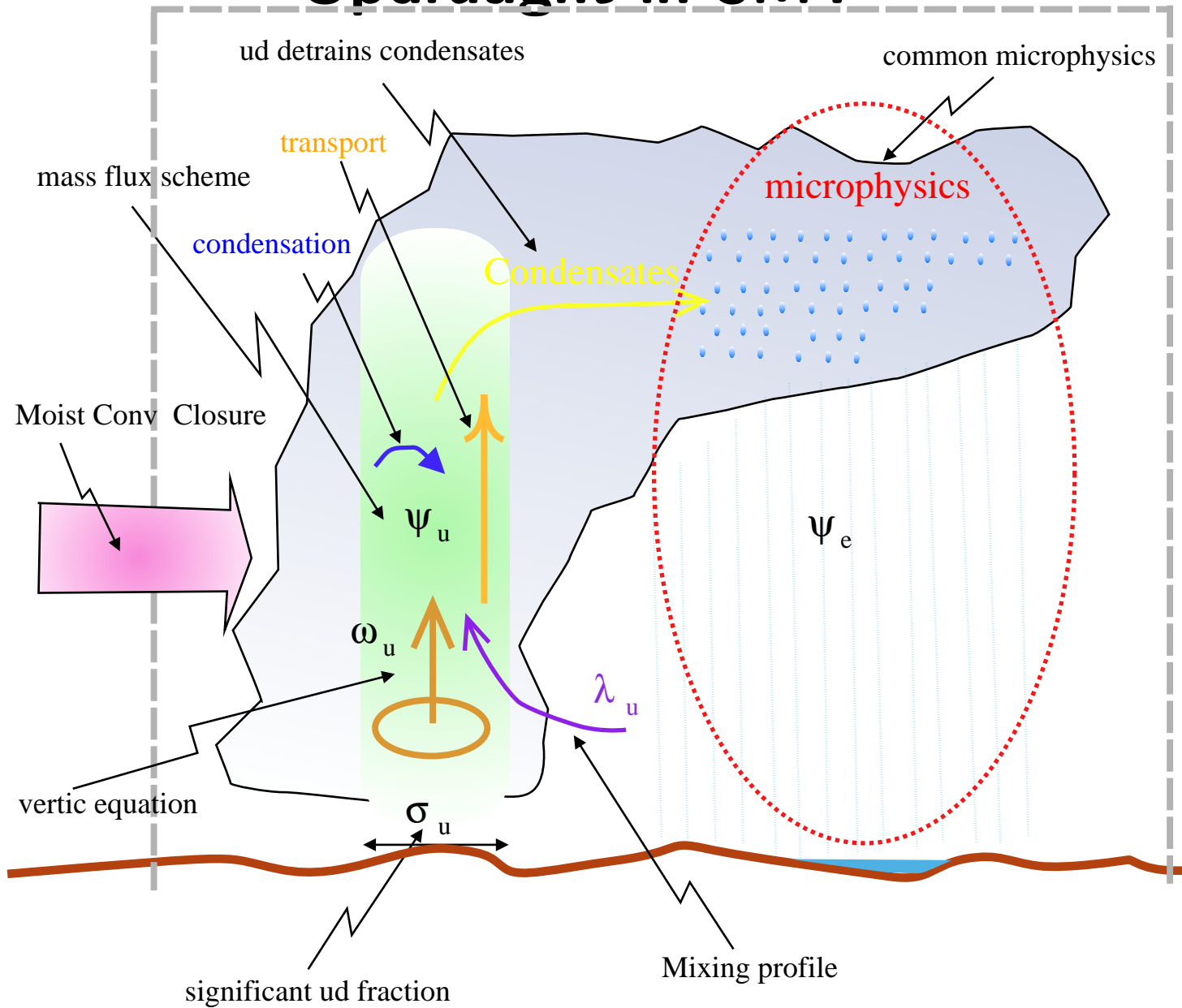

# Closure in 3MT

- Closure is not the same in an MT scheme as in the Bougeault scheme

$$\frac{\partial \sigma_u}{\partial t} \int_{p_t}^{p_b} (h_u - \bar{h}) \frac{dp}{g} = L \int_{p_t}^{p_b} \sigma_u \omega_u^* \frac{\delta q_{cu}}{g} + \alpha_{cvg} L \int_{p_t}^{p_b} \text{CVGQ} \frac{dp}{g}$$

# Closure in 3MT

- Closure is not the same in an MT scheme as in the Bougeault scheme

$$\frac{\partial \sigma_u}{\partial t} \int_{p_t}^{p_b} (h_u - \bar{h}) \frac{dp}{g} = L \int_{p_t}^{p_b} \sigma_u \omega_u^* \frac{\delta q_{cu}}{g} + \alpha_{cvg} L \int_{p_t}^{p_b} CVGQ \frac{dp}{g}$$

$$LCVGQM=.F. \iff RMULACVG=1.$$

# Closure in 3MT

- Closure is not the same in an MT scheme as in the Bougeault scheme

$$\frac{\partial \sigma_u}{\partial t} \int_{p_t}^{p_b} (h_u - \bar{h}) \frac{dp}{g} = L \int_{p_t}^{p_b} \sigma_u \omega_u^* \frac{\delta q_{cu}}{g} + \alpha_{cvg} L \int_{p_t}^{p_b} CVGQ \frac{dp}{g}$$

$$LCVGQM=.F. \iff RMULACVG=1.$$

- Moving QE hypothesis

# Closure in 3MT

- Closure is not the same in an MT scheme as in the Bougeault scheme

$$\frac{\partial \sigma_u}{\partial t} \int_{p_t}^{p_b} (h_u - \bar{h}) \frac{dp}{g} = L \int_{p_t}^{p_b} \sigma_u \omega_u^* \frac{\delta q_{cu}}{g} + \alpha_{cvg} L \int_{p_t}^{p_b} CVGQ \frac{dp}{g}$$

$$LCVGQM=.F. \iff RMULACVG=1.$$

- Moving QE hypothesis

*”Forcing” is counter-balanced by updraught activity to maintain some steady state*

# Closure in 3MT

- Closure is not the same in an MT scheme as in the Bougeault scheme

$$\frac{\partial \sigma_u}{\partial t} \int_{p_t}^{p_b} (h_u - \bar{h}) \frac{dp}{g} = L \int_{p_t}^{p_b} \sigma_u \omega_u^* \frac{\delta q_{cu}}{g} + \alpha_{cvg} L \int_{p_t}^{p_b} CVGQ \frac{dp}{g}$$

$$LCVGQM=.F. \iff RMULACVG=1.$$

- Moving QE hypothesis

*”Forcing” is counter-balanced by updraught activity  
to maintain some steady state*



*resolved  $q_v$  “maintained” by condensation in the updraught*

# Closure in 3MT

- Closure is not the same in an MT scheme as in the Bougeault scheme

$$\frac{\partial \sigma_u}{\partial t} \int_{p_t}^{p_b} (h_u - \bar{h}) \frac{dp}{g} = L \int_{p_t}^{p_b} \sigma_u \omega_u^* \frac{\delta q_{cu}}{g} + \alpha_{cvg} L \int_{p_t}^{p_b} CVGQ \frac{dp}{g}$$

$$LCVGQM=.F. \iff RMULACVG=1.$$

- Moving QE hypothesis

*”Forcing” is counter-balanced by updraught activity  
to maintain some steady state*



*resolved  $q_v$  “maintained” by condensation in the updraught*

$\implies$  CVGQ used for scaling...

# Closure in 3MT

- Closure is not the same in an MT scheme as in the Bougeault scheme

$$\frac{\partial \sigma_u}{\partial t} \int_{p_t}^{p_b} (h_u - \bar{h}) \frac{dp}{g} = L \int_{p_t}^{p_b} \sigma_u \omega_u^* \frac{\delta q_{cu}}{g} + \alpha_{cvg} L \int_{p_t}^{p_b} CVGQ \frac{dp}{g}$$

$$LCVGQM=.F. \iff RMULACVG=1.$$

- Moving QE hypothesis

*”Forcing” is counter-balanced by updraught activity  
to maintain some steady state*



*resolved  $q_v$  “maintained” by condensation in the updraught*

$\implies$  CVGQ used for scaling...

...while local turbulent diffusion acts on buoyancy profile!



# Cascade and closure

# Cascade and closure

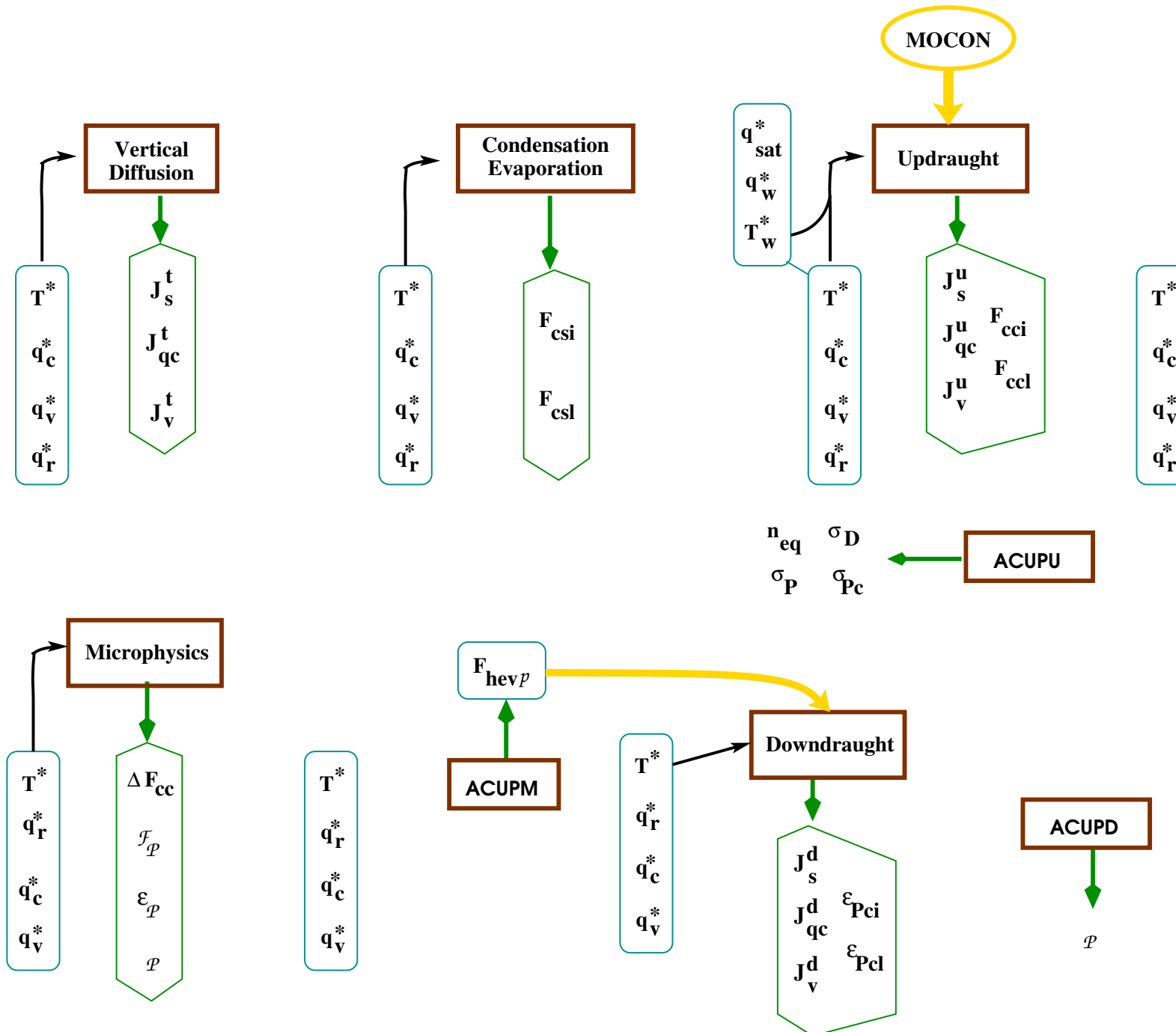

# Cascade and closure

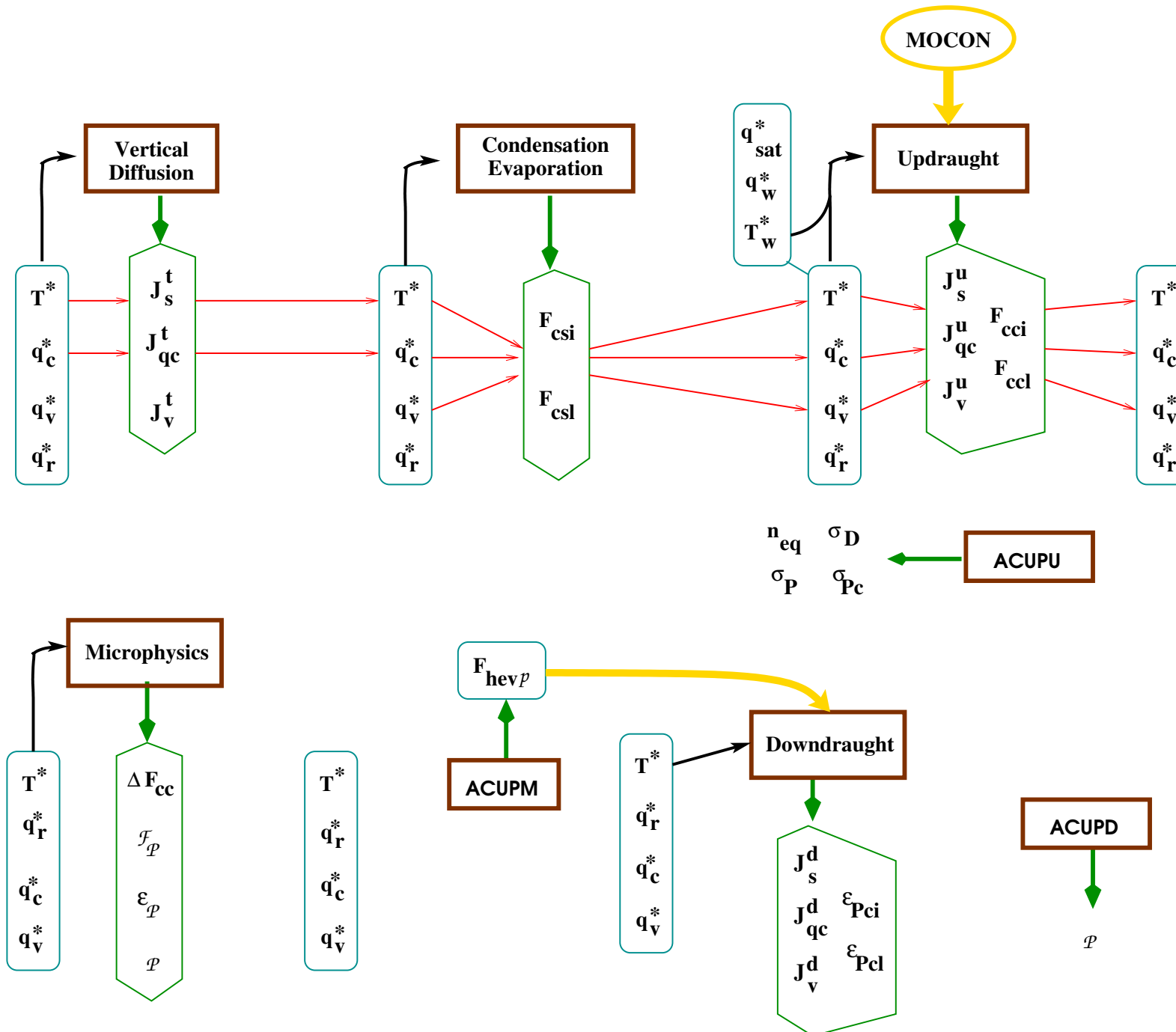

# Cascade and closure

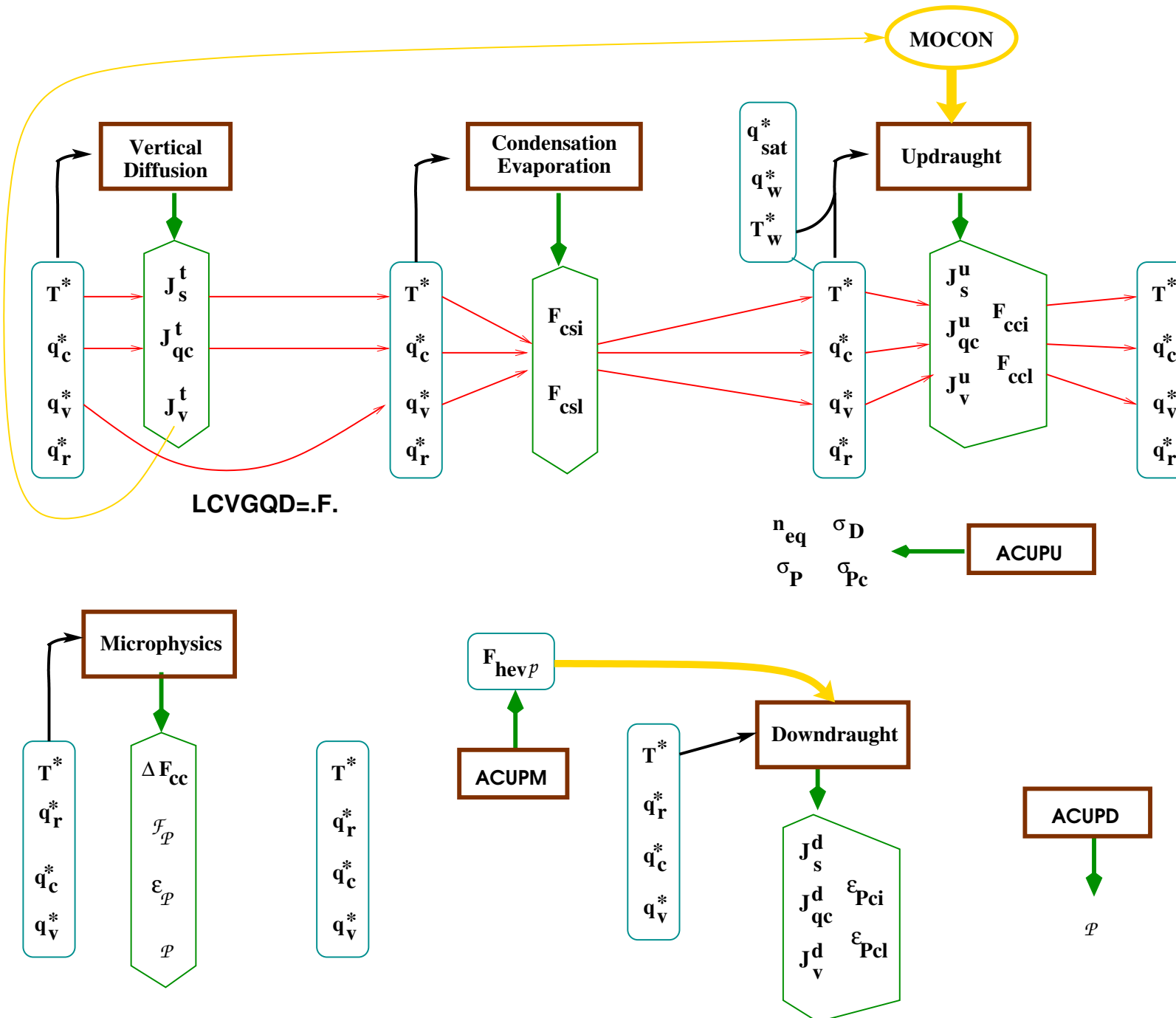

# Cascade and closure

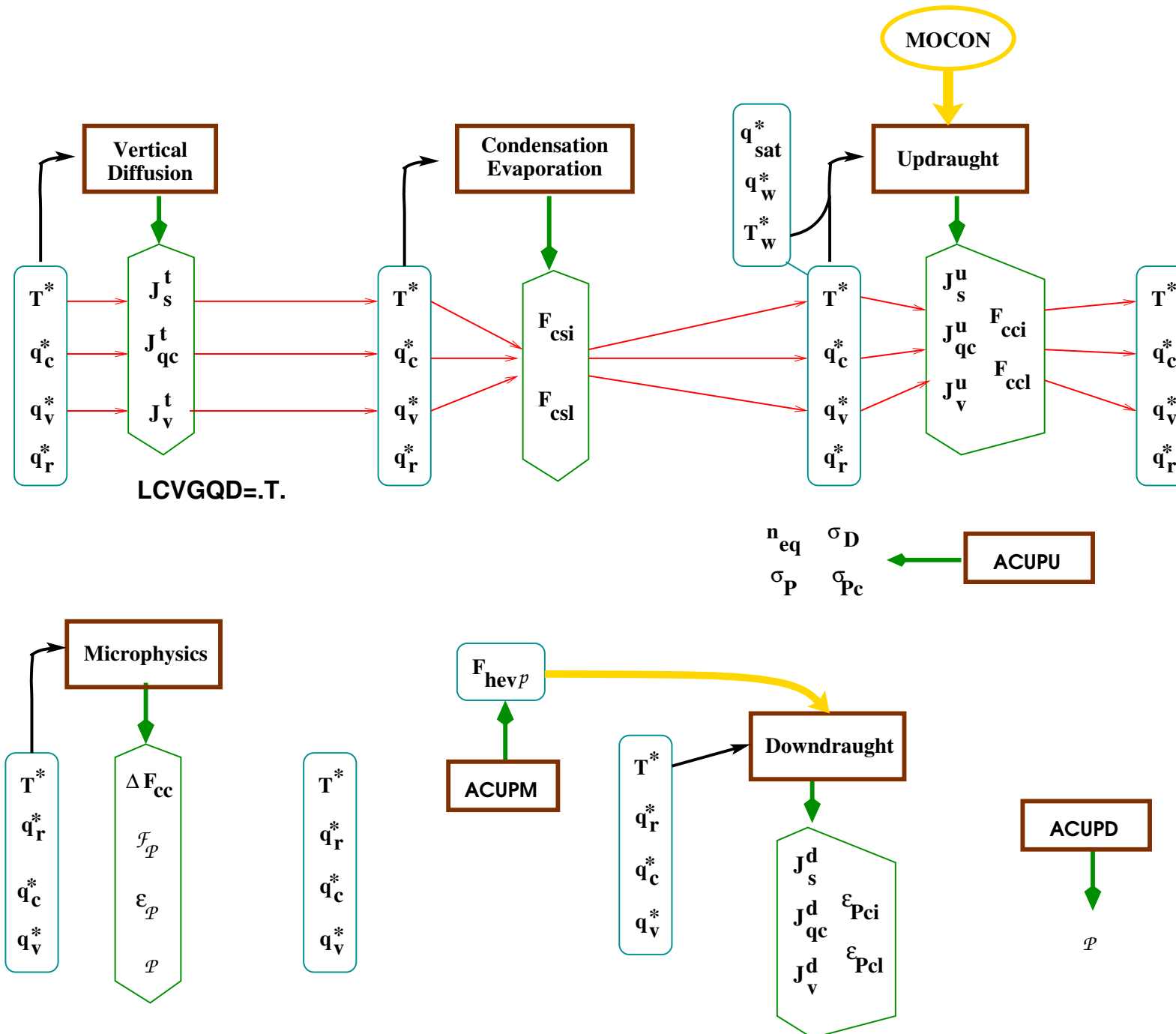

# Cascade and closure

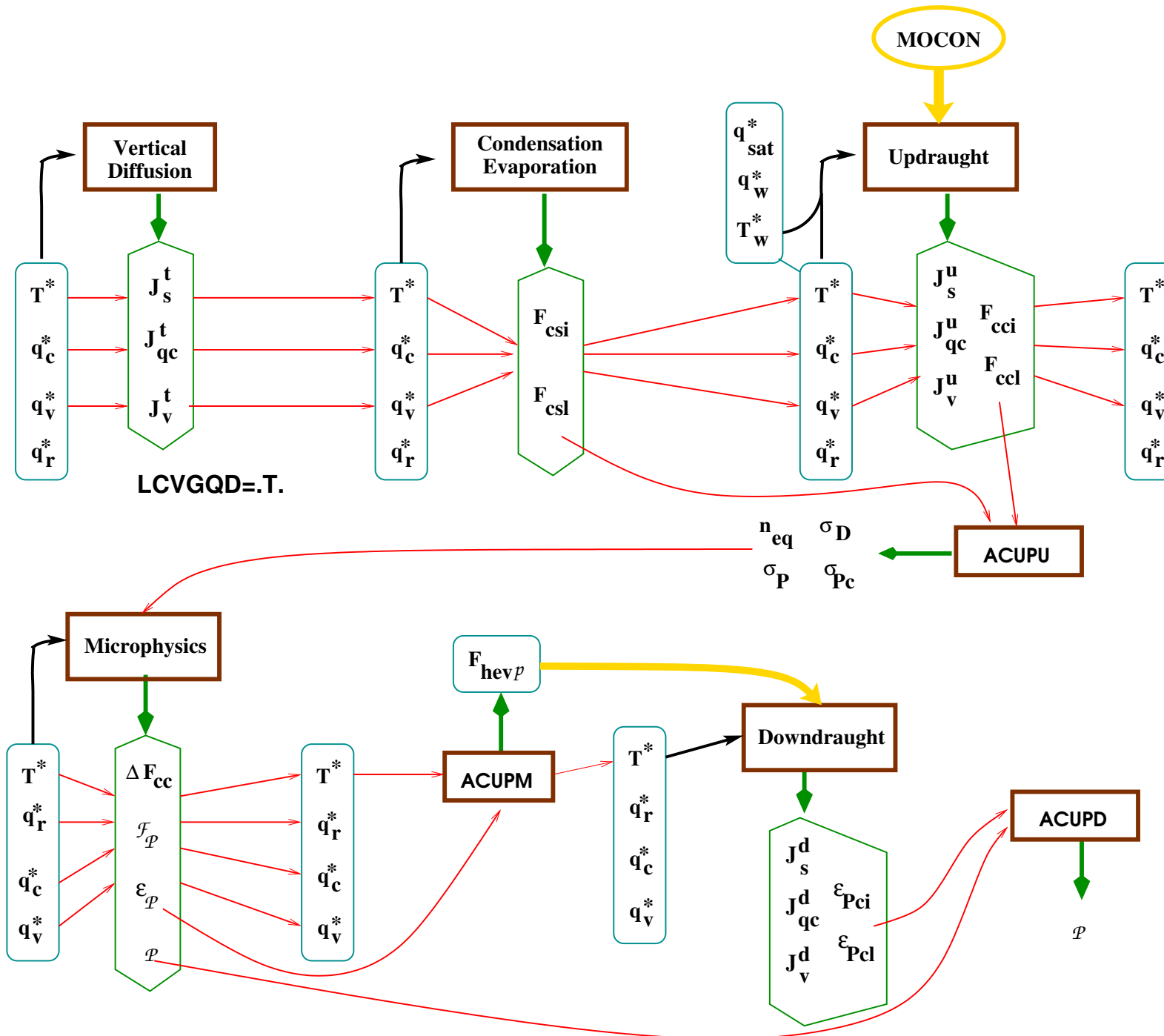

# Cascade and closure

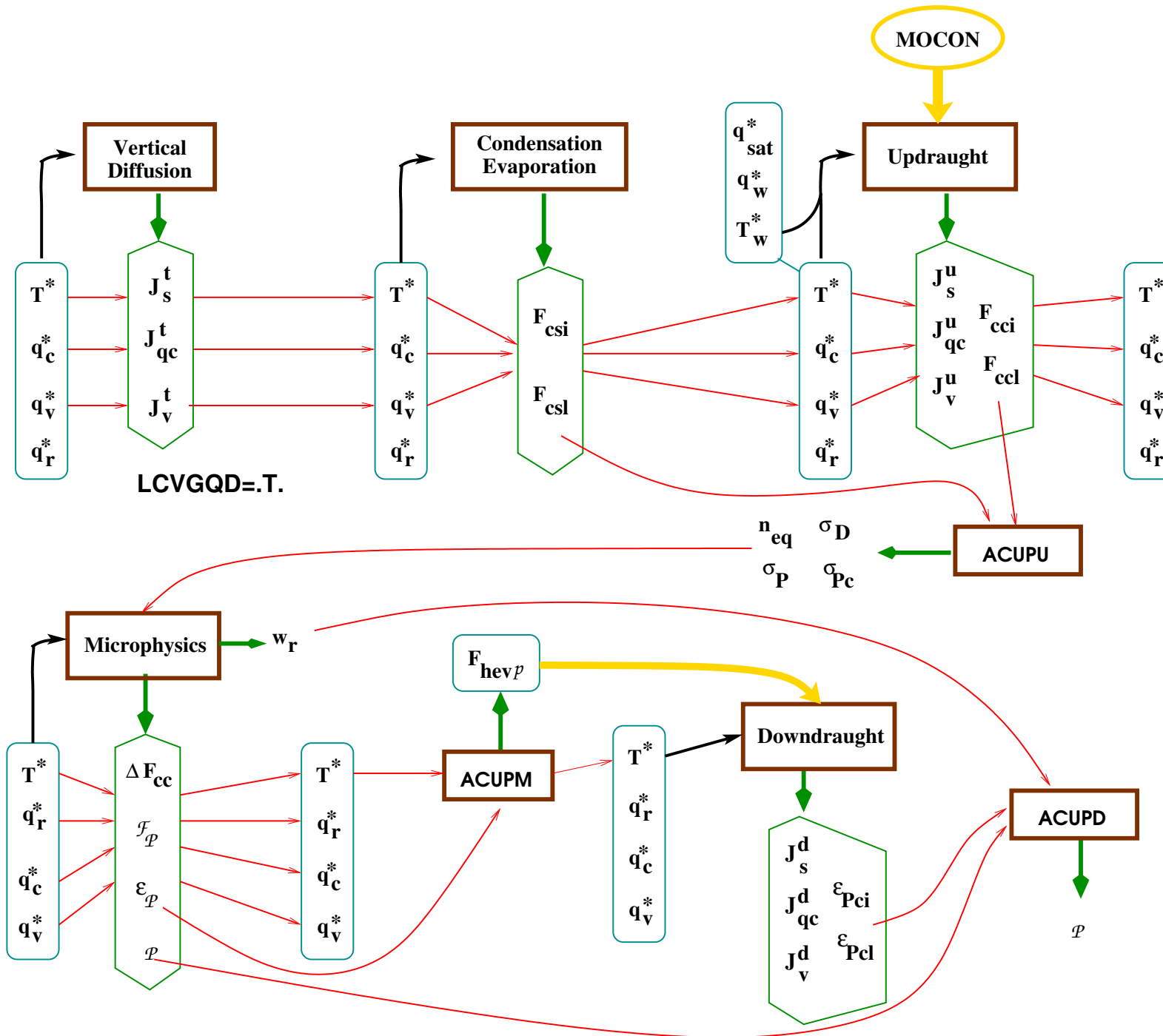

# Cascade and closure

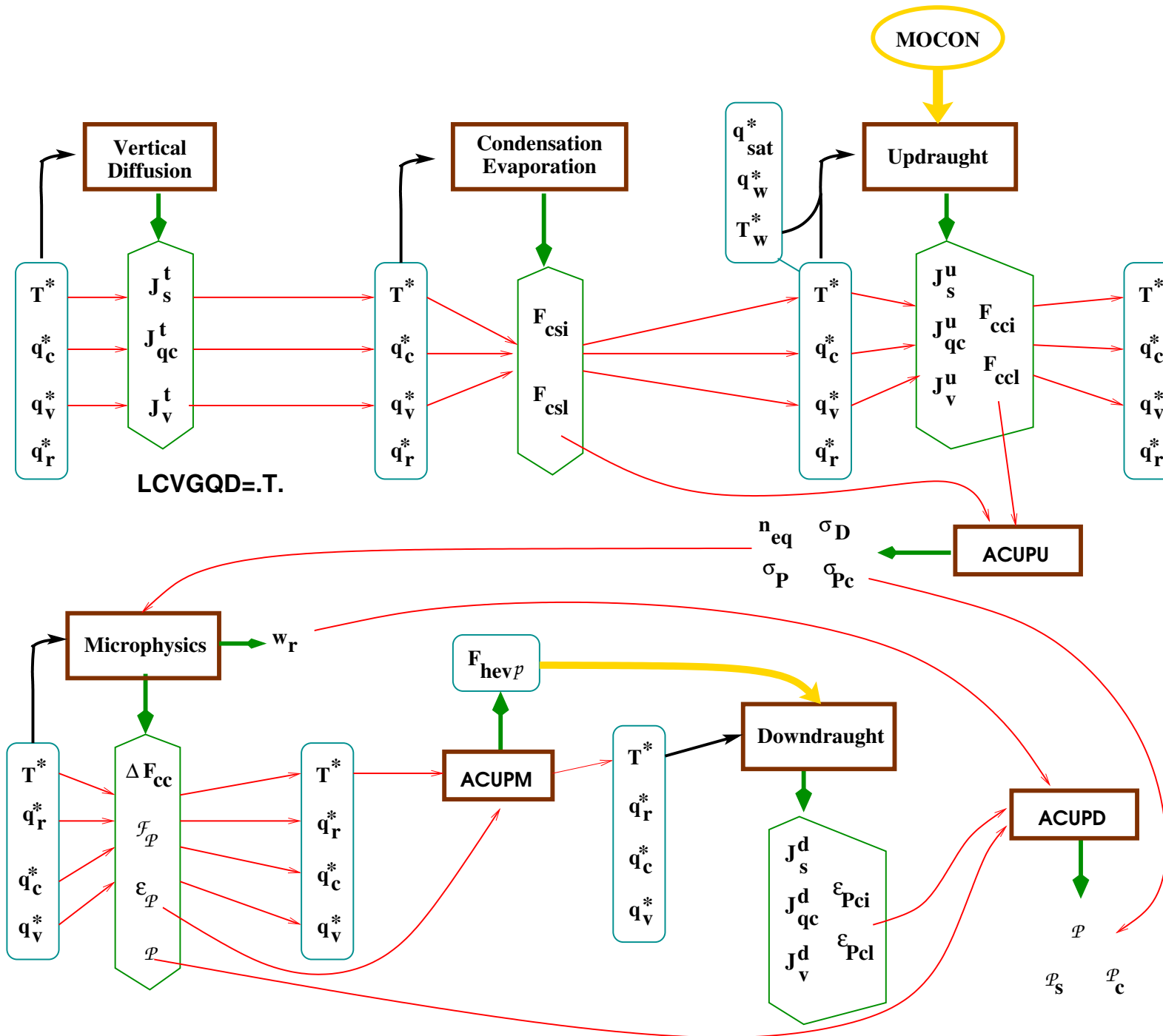



# Entraining ascent segment

# Entraining ascent segment

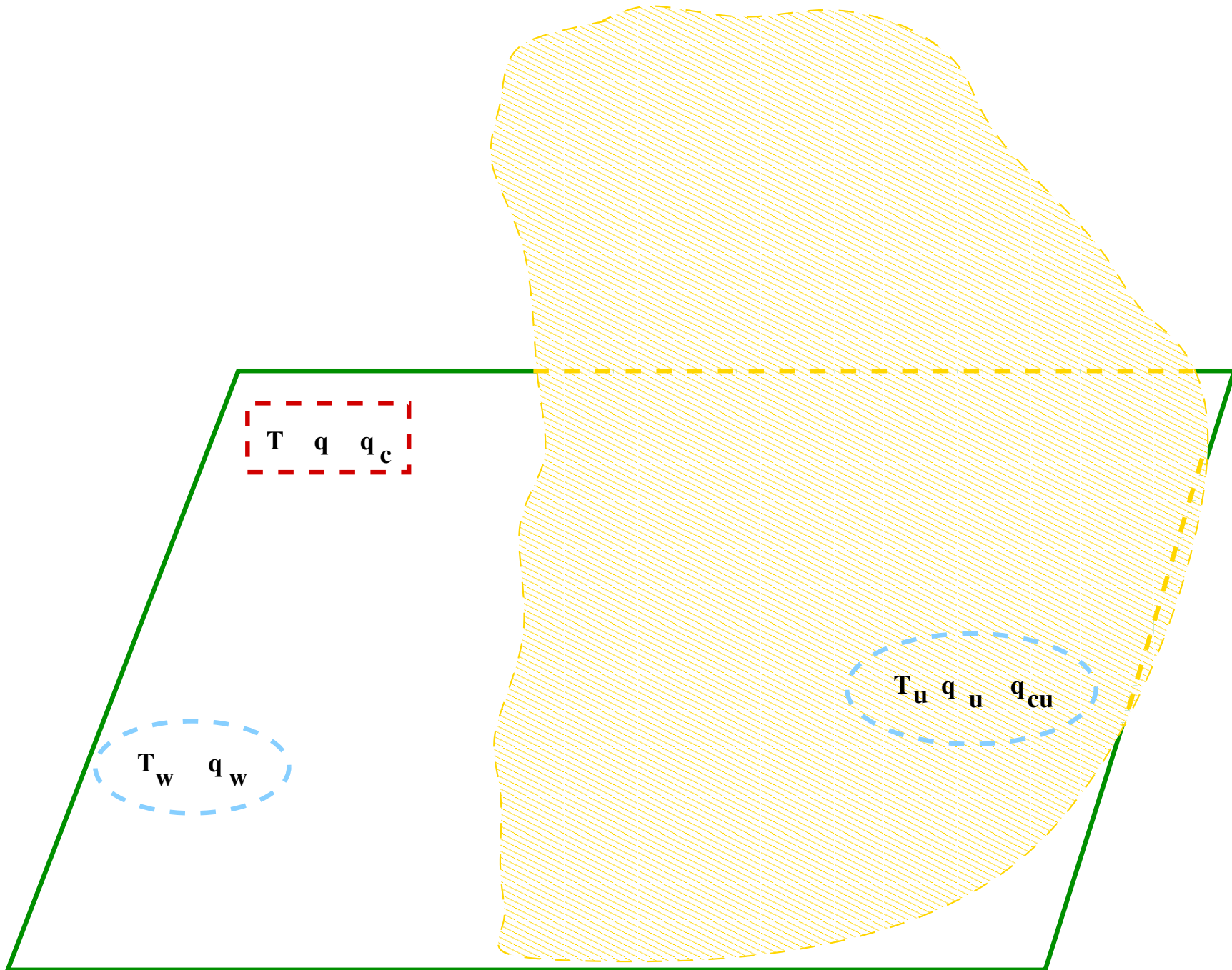

# Entraining ascent segment

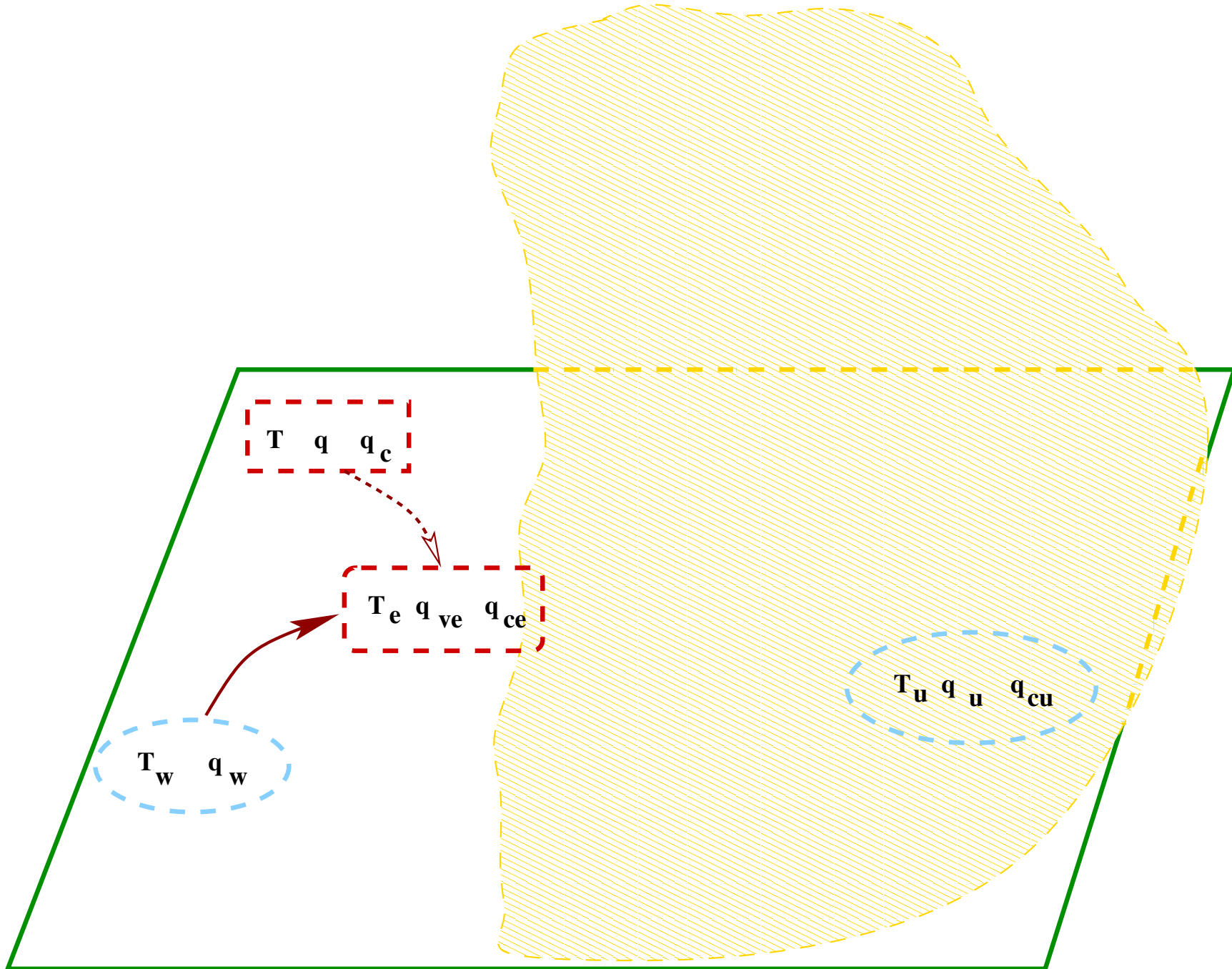

# Entraining ascent segment

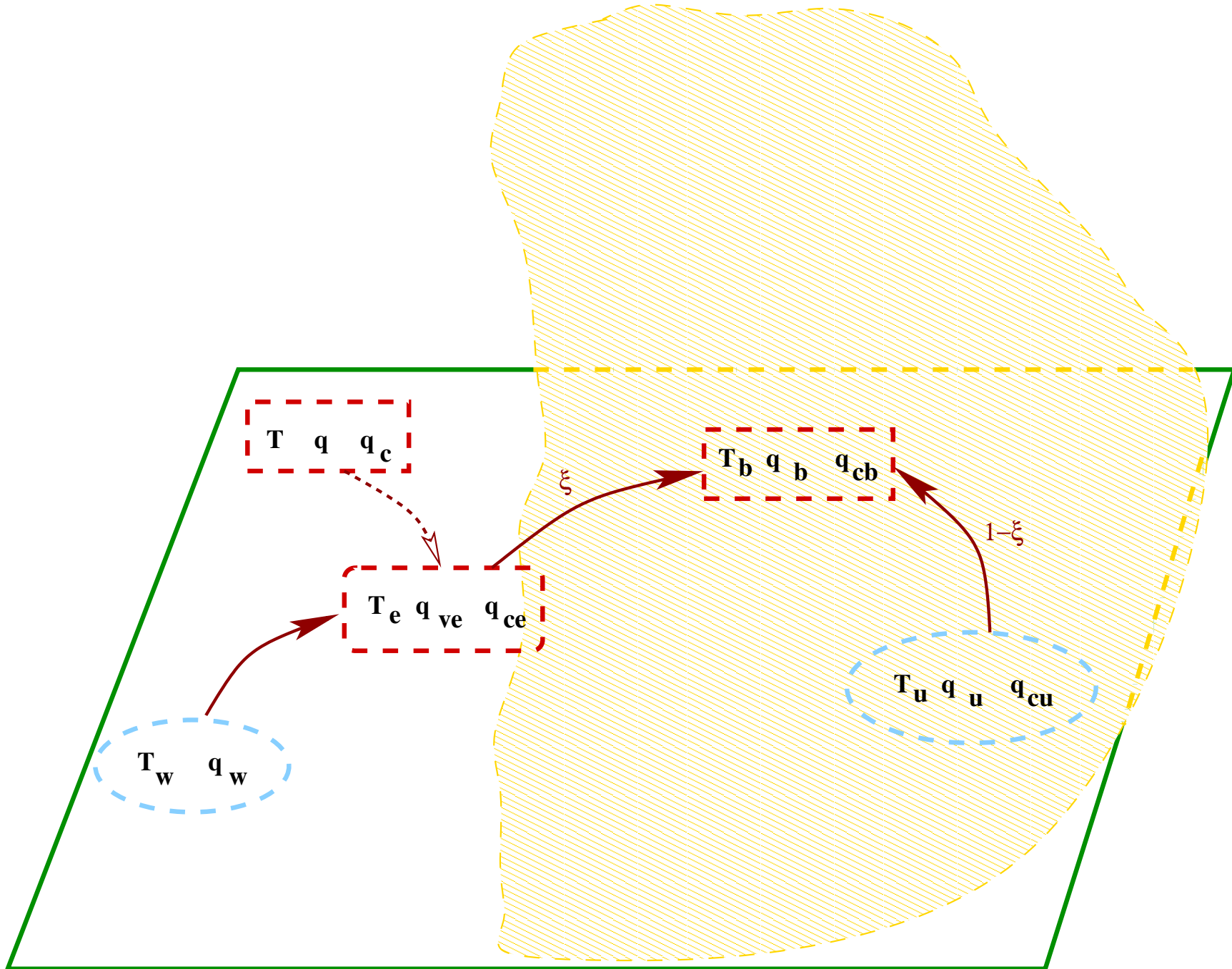

# Entraining ascent segment

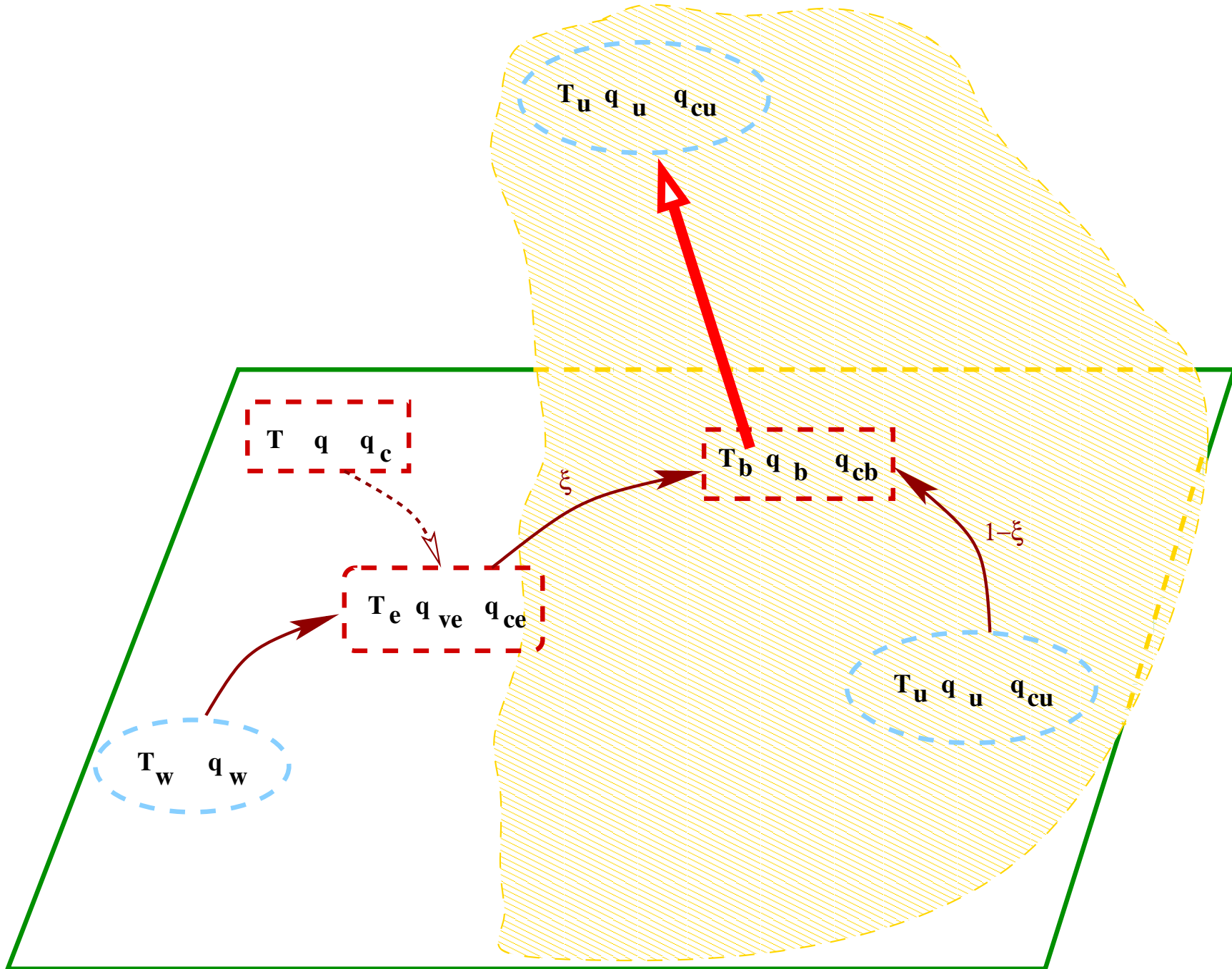

# Entraining ascent segment

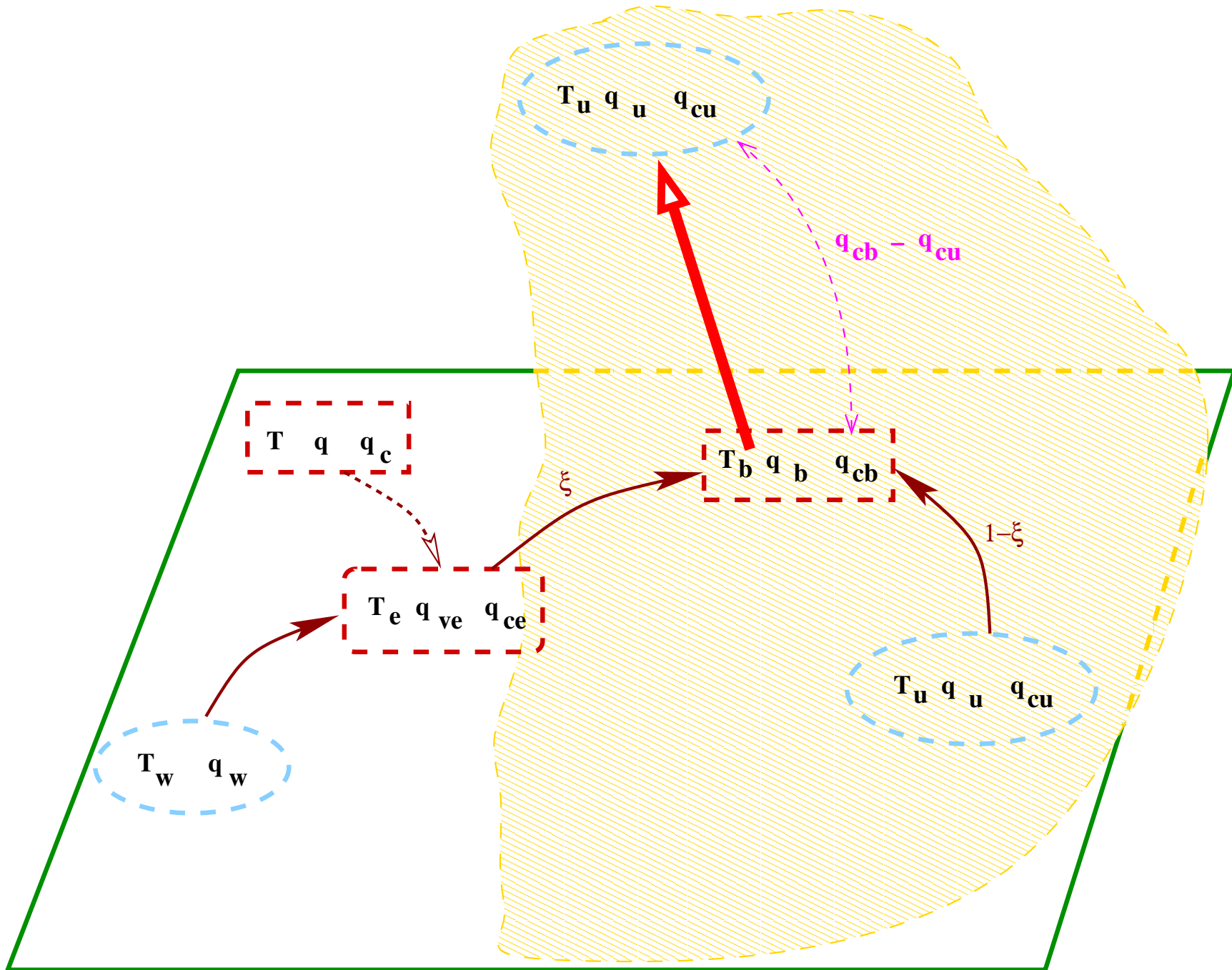

# Entraining ascent segment

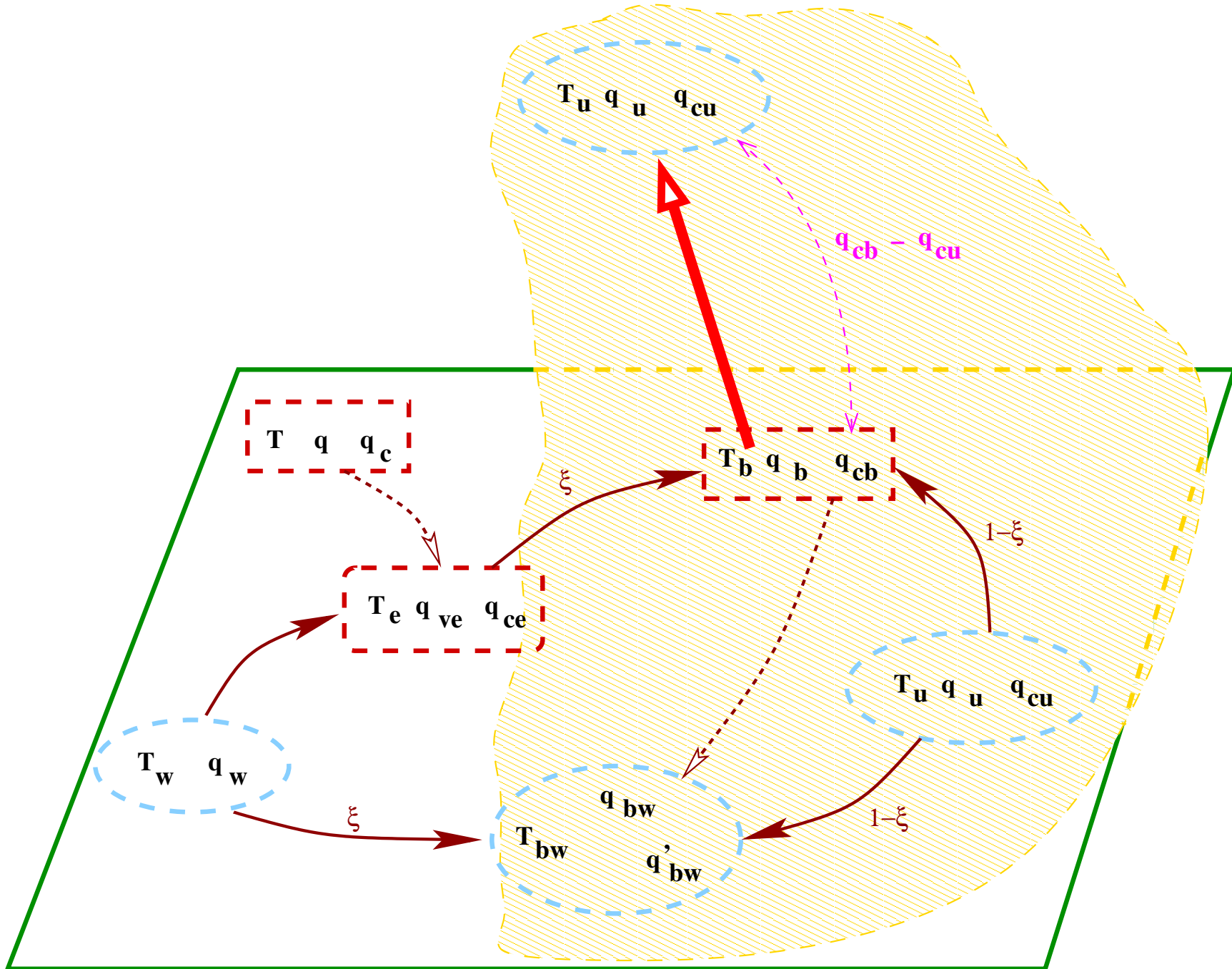

# Entraining ascent segment

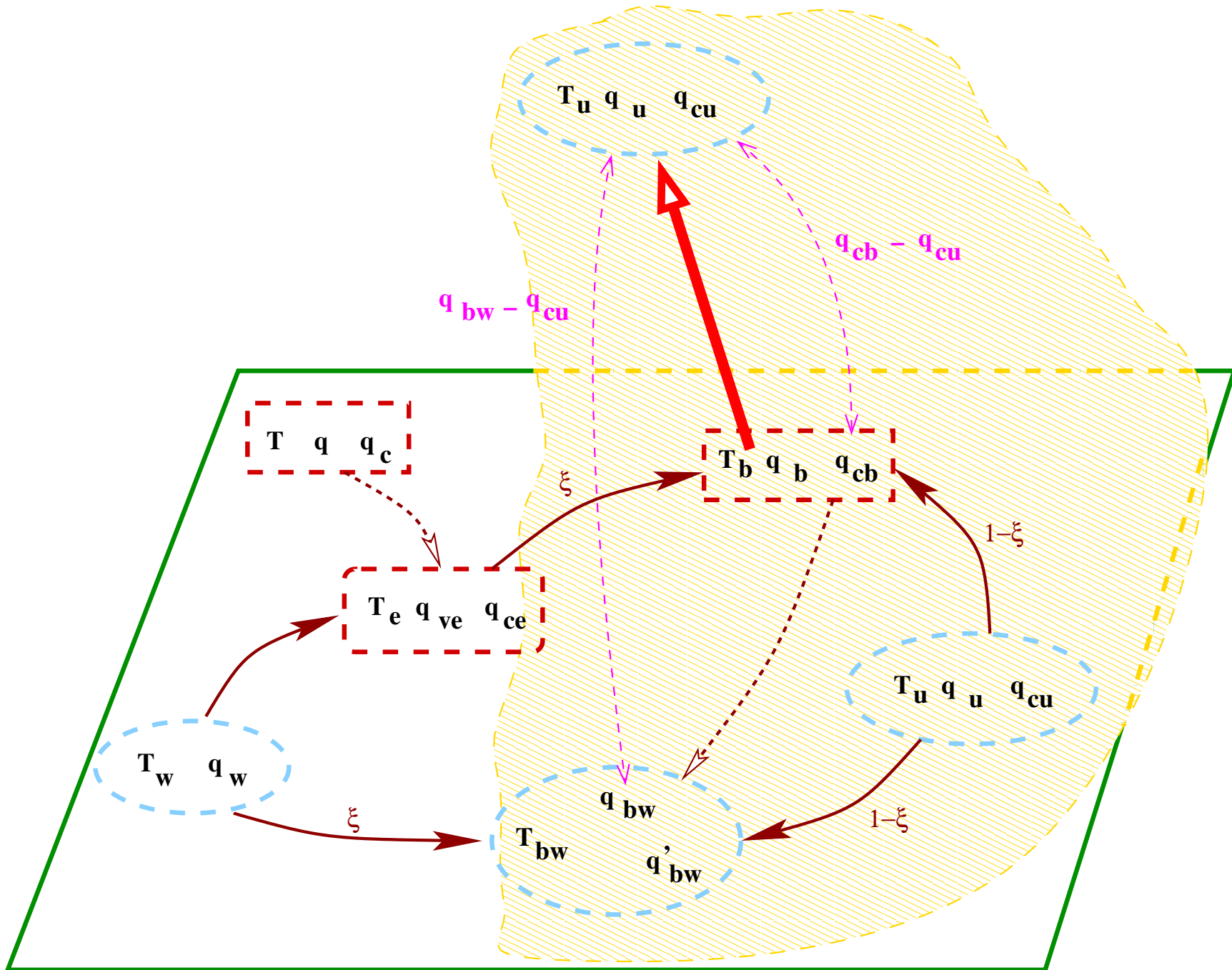



# Detrainment Area

# Detrainment Area

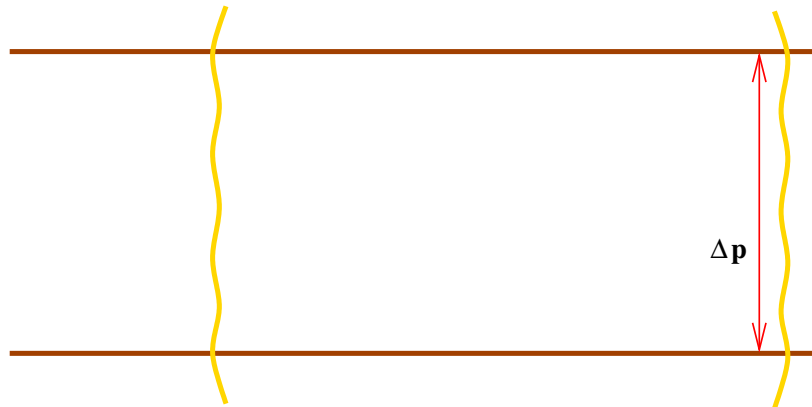

Condensate budget

LLDEQC=.T.

# Detrainment Area

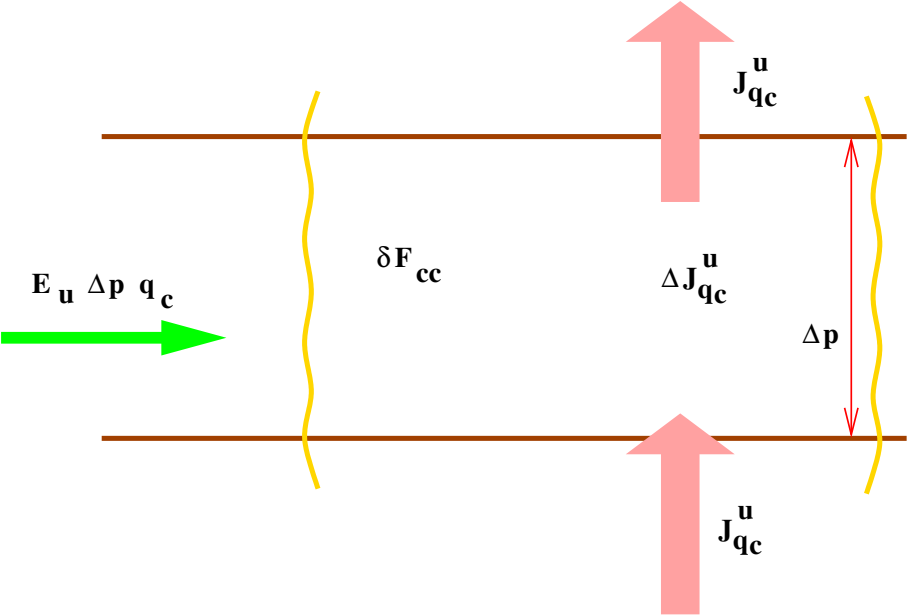

Condensate budget

$$LLDEQC = .T.$$

# Detrainment Area

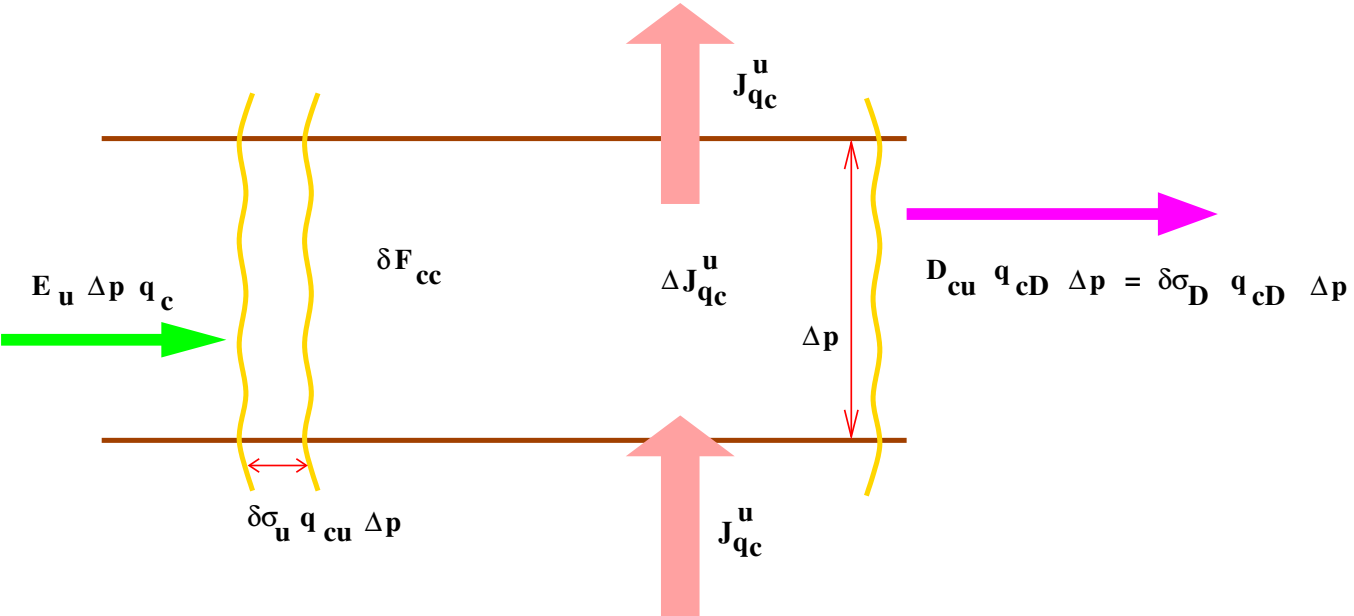

Condensate budget

$LLDEQC = .T.$

# Detrainment Area

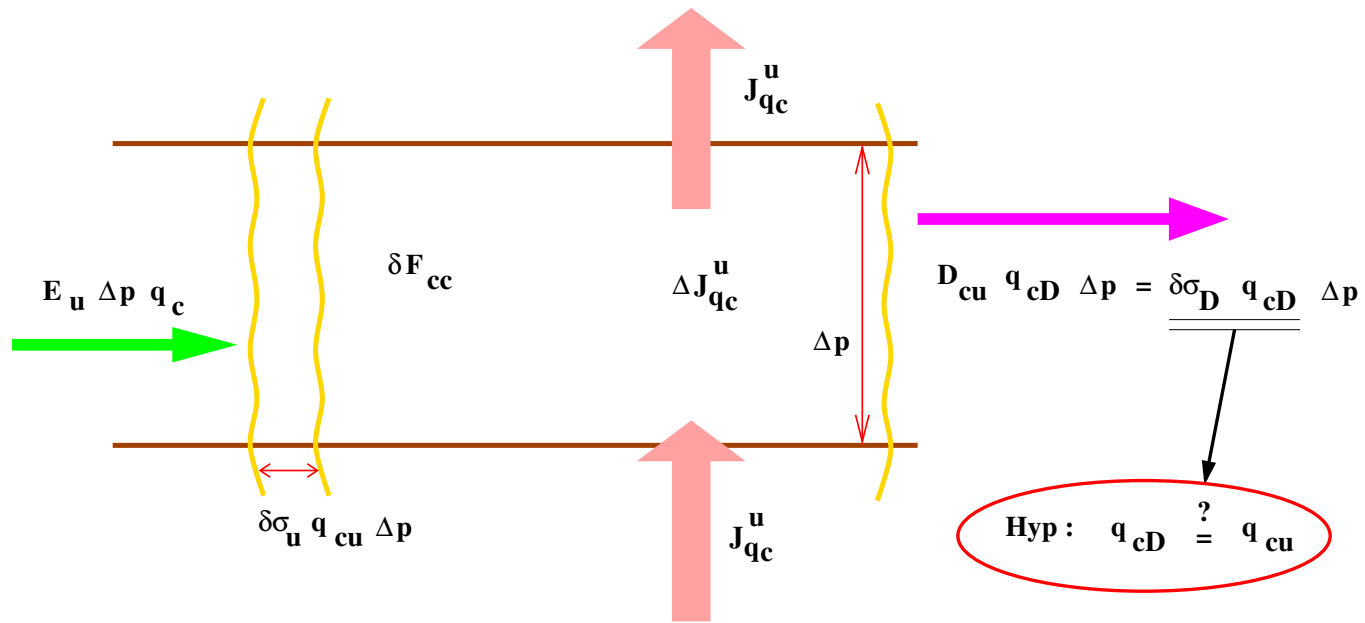

Condensate budget

LLDEQC=.T.

# Detrainment Area

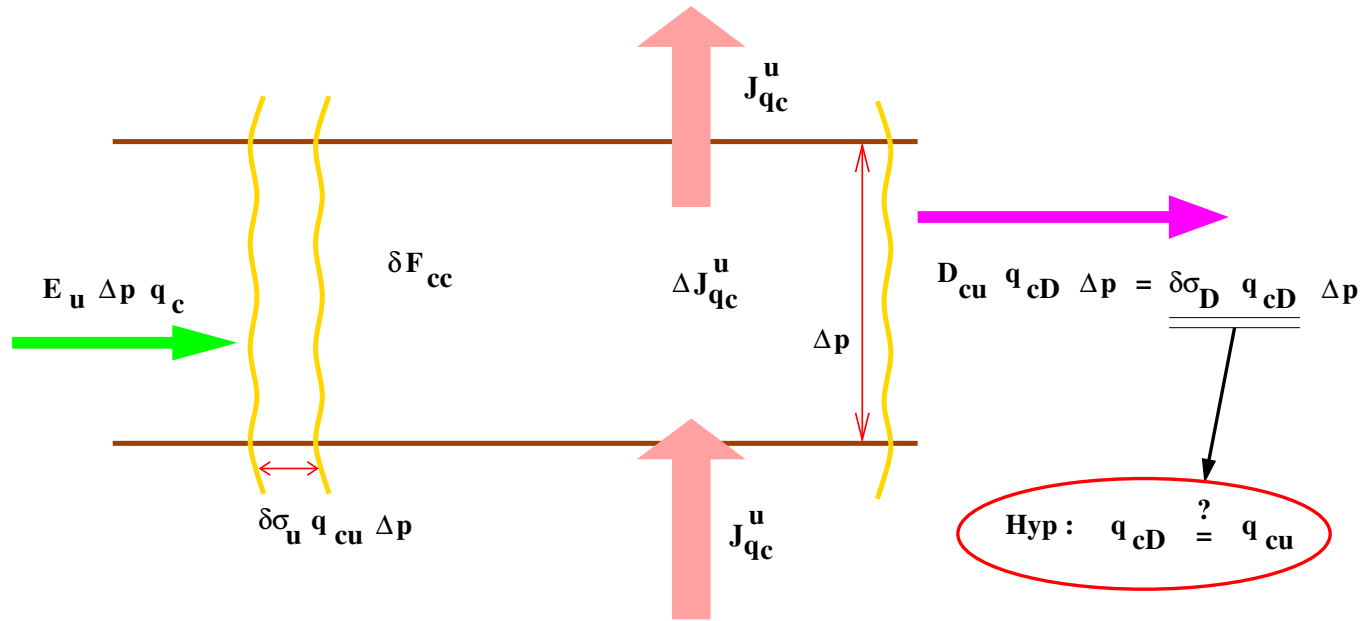

Condensate budget

$$LLDEQC = .T.$$

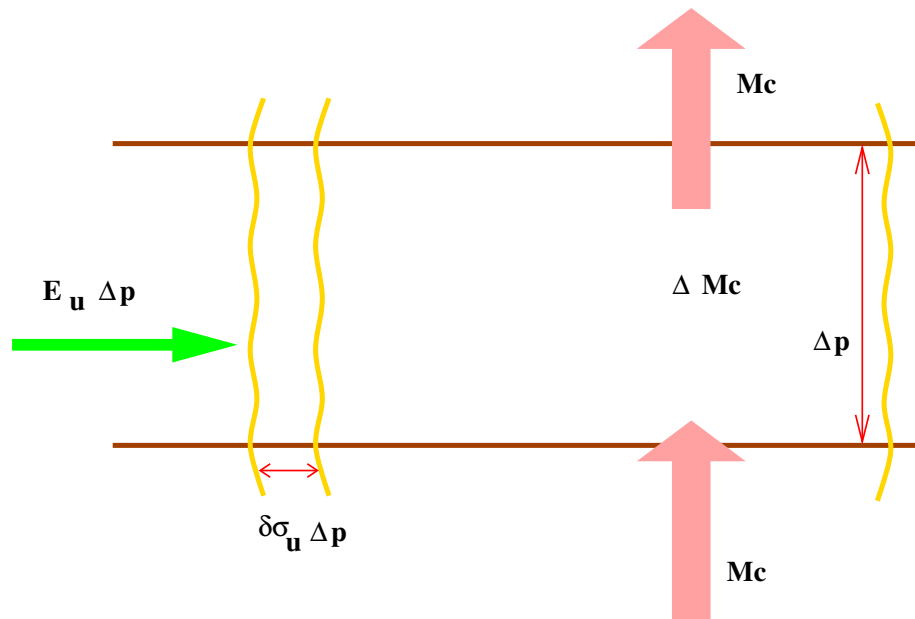

Mass budget

$$LLDEQC = .F.$$

# Detrainment Area

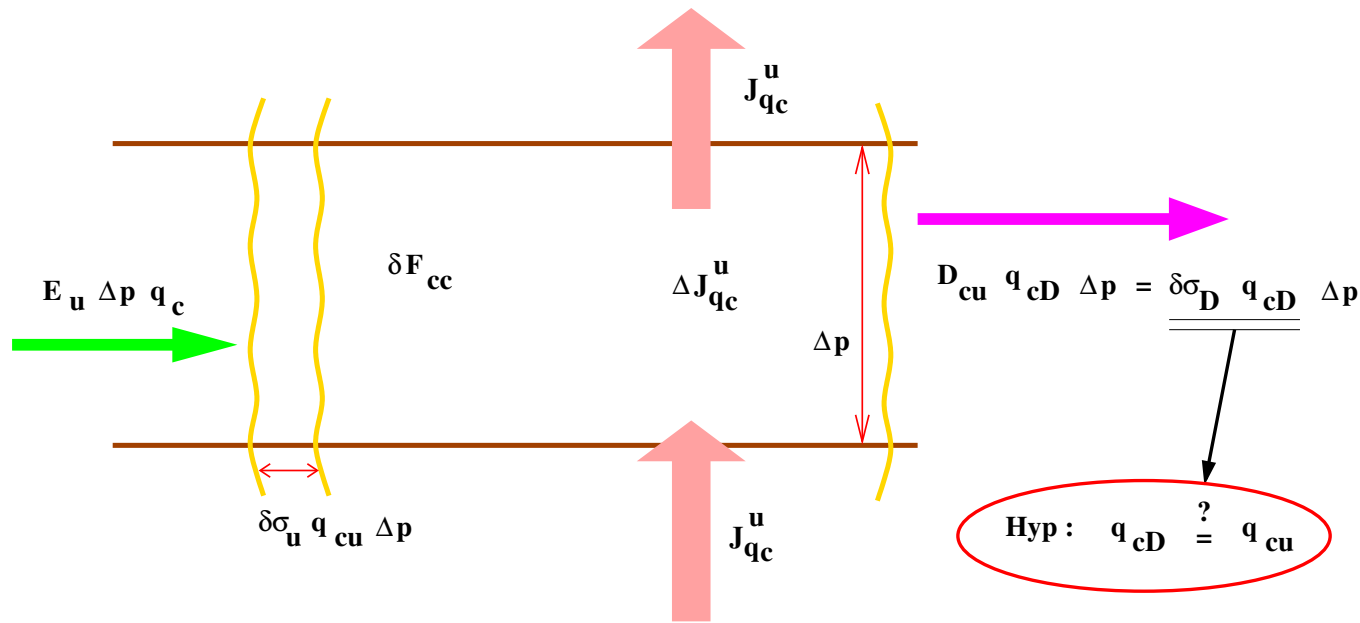

Condensate budget

$$LLDEQC = .T.$$

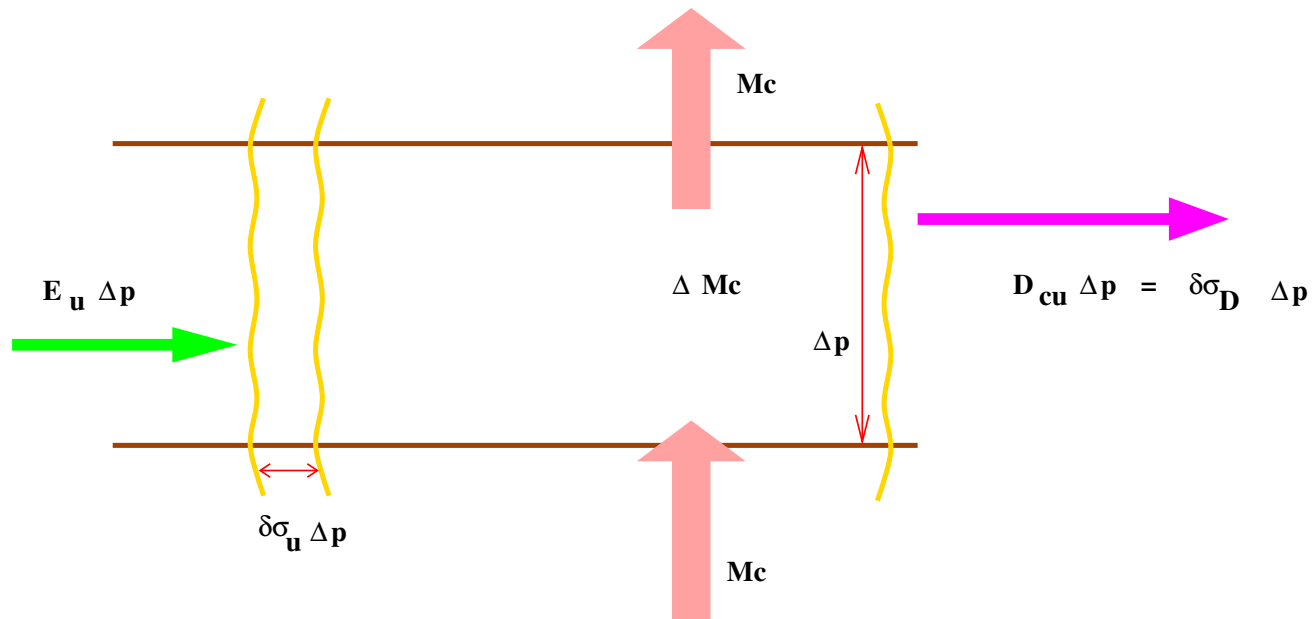

Mass budget

$$LLDEQC = .F.$$

# Relation to convective fractions

$\sigma_D \neq \delta\sigma_D \Rightarrow$ accumulation

$$\sigma_D^+ = \min(1 - \sigma_u^+, \sigma_D^- \cdot e^{-\frac{\Delta t}{\tau}} + \delta\sigma_D)$$

$$n_c = \sigma_u + \sigma_D$$

GCVTAUDE : half-life of detrained cloud



# Relation to convective fractions

$\sigma_D \neq \delta\sigma_D \Rightarrow$  accumulation

$$\sigma_D^+ = \min(1 - \sigma_u^+, \sigma_D^- \cdot e^{-\frac{\Delta t}{\tau}} + \delta\sigma_D)$$

$$n_c = \sigma_u + \sigma_D$$

GCVTAUDE : half-life of detrained cloud

Fraction of convective precipitation :  $\sigma_{\mathcal{P}_c} = \frac{\Delta F_{cc}}{\Delta F_{cc} + \Delta F_{cs}}$

# Relation to convective fractions

$\sigma_D \neq \delta\sigma_D \Rightarrow$  accumulation

$$\sigma_D^+ = \min(1 - \sigma_u^+, \sigma_D^- \cdot e^{-\frac{\Delta t}{\tau}} + \delta\sigma_D)$$

$$n_c = \sigma_u + \sigma_D$$

GCVTAUDE : half-life of detrained cloud

Fraction of convective precipitation :  $\sigma_{\mathcal{P}_c} = \frac{\Delta F_{cc}}{\Delta F_{cc} + \Delta F_{cs}}$

Convective cloud fraction is protected against re-evaporation :  $\sigma_{\text{prot}} = \frac{n_c^-}{n_c^- + n_s^+ - n_c^- n_s^+}$

# Relation to convective fractions

$\sigma_D \neq \delta\sigma_D \Rightarrow$  accumulation

$$\sigma_D^+ = \min(1 - \sigma_u^+, \sigma_D^- \cdot e^{-\frac{\Delta t}{\tau}} + \delta\sigma_D)$$

$$n_c = \sigma_u + \sigma_D$$

GCVTAUDE : half-life of detrained cloud

Fraction of convective precipitation :  $\sigma_{\mathcal{P}_c} = \frac{\Delta F_{cc}}{\Delta F_{cc} + \Delta F_{cs}}$

Convective cloud fraction is protected against re-evaporation :  $\sigma_{\text{prot}} = \frac{n_c^-}{n_c^- + n_s^+ - n_c^- n_s^+}$

... $\sigma_{\text{prot}}$  significantly larger than  $\sigma_{\mathcal{P}_c}$  (e.g. 3 times)

# Tt and mixed phase problems

# Tt and mixed phase problems

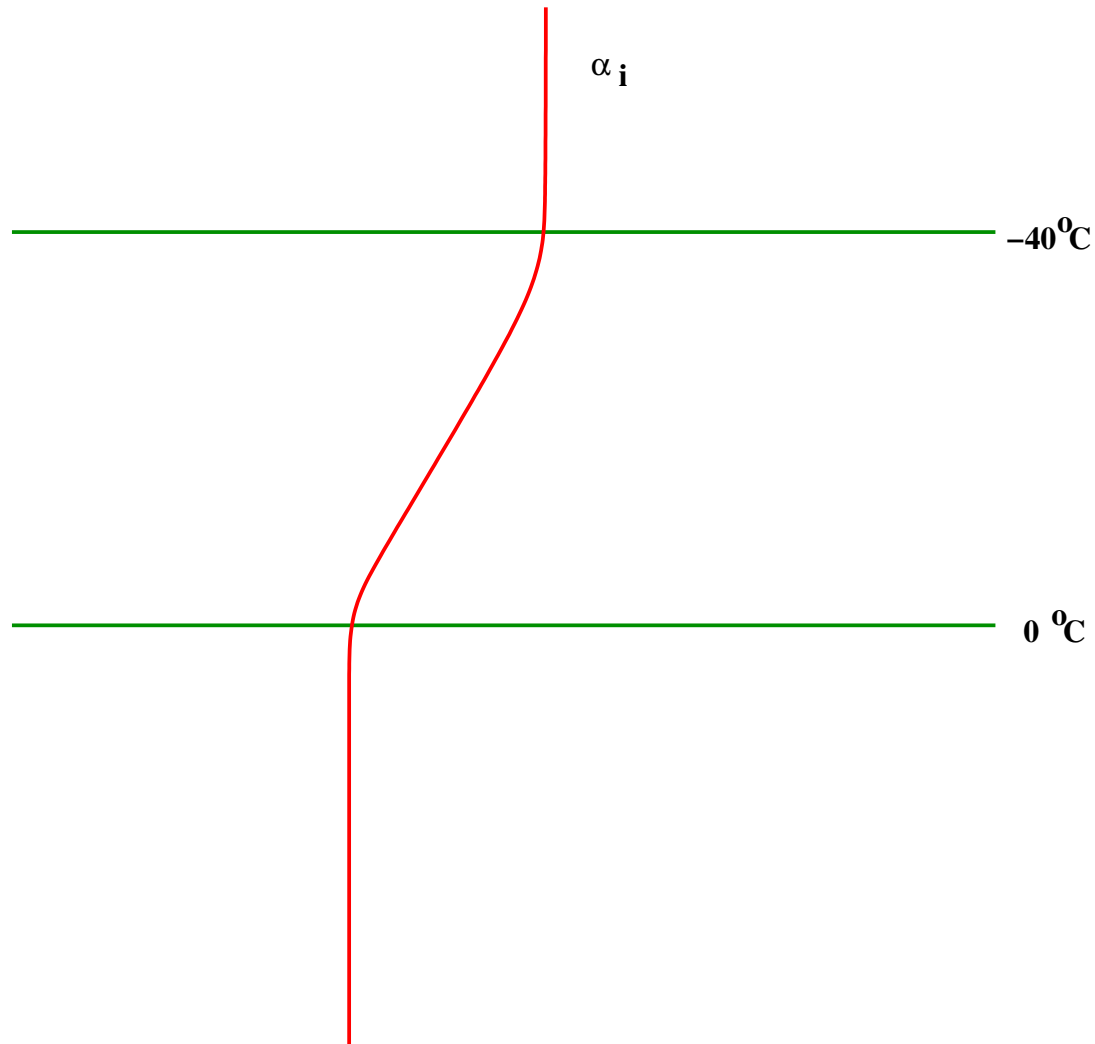

Statistic  $\alpha_i$  profile  
Newton loop does not include  $\frac{\partial \alpha_i}{\partial T}$

# Tt and mixed phase problems

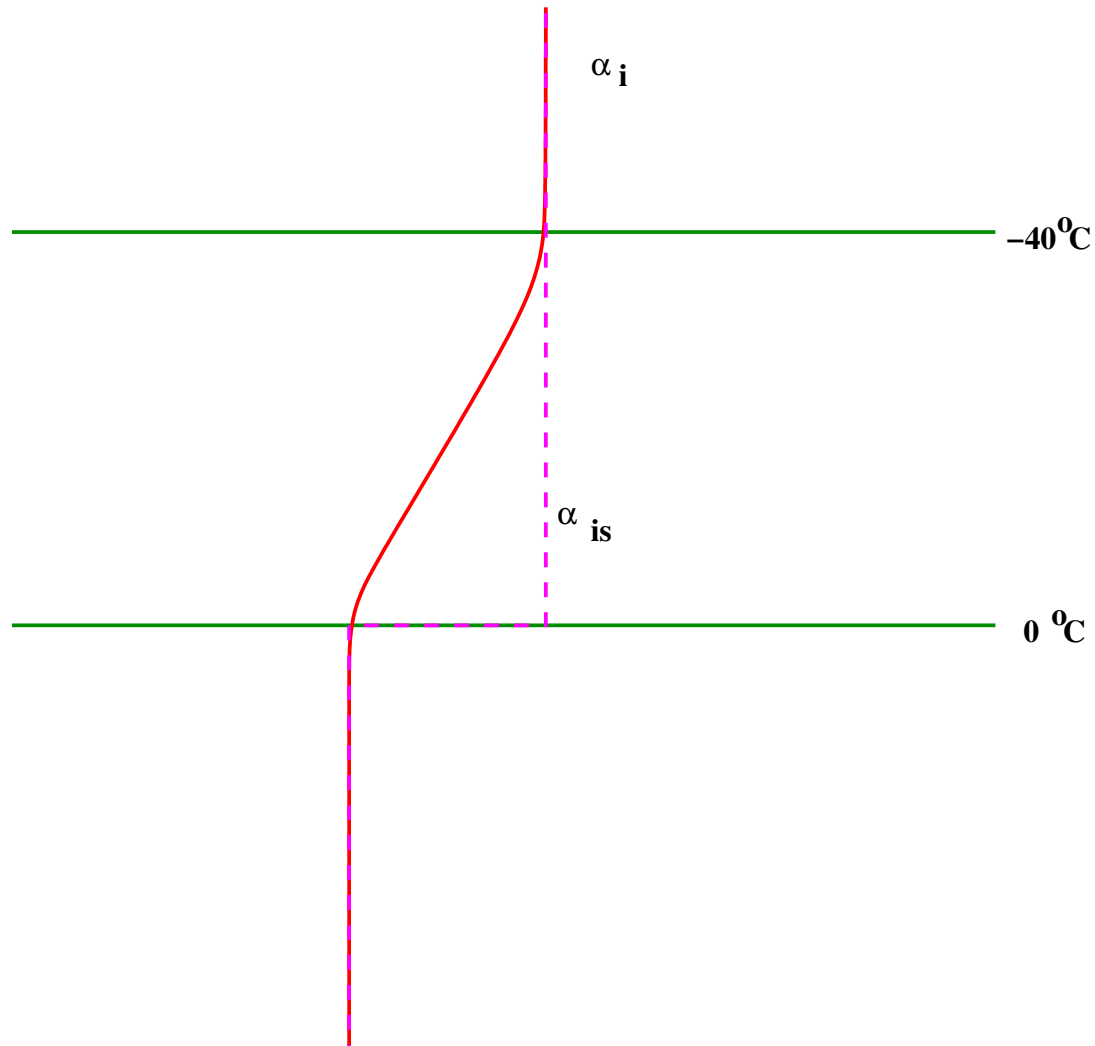

Statistic  $\alpha_i$  profile

Newton loop does not include  $\frac{\partial \alpha_i}{\partial T}$

Use instead  $\alpha_{is}$  step profile

and keep it constant in Newton loop

# Tt and mixed phase problems

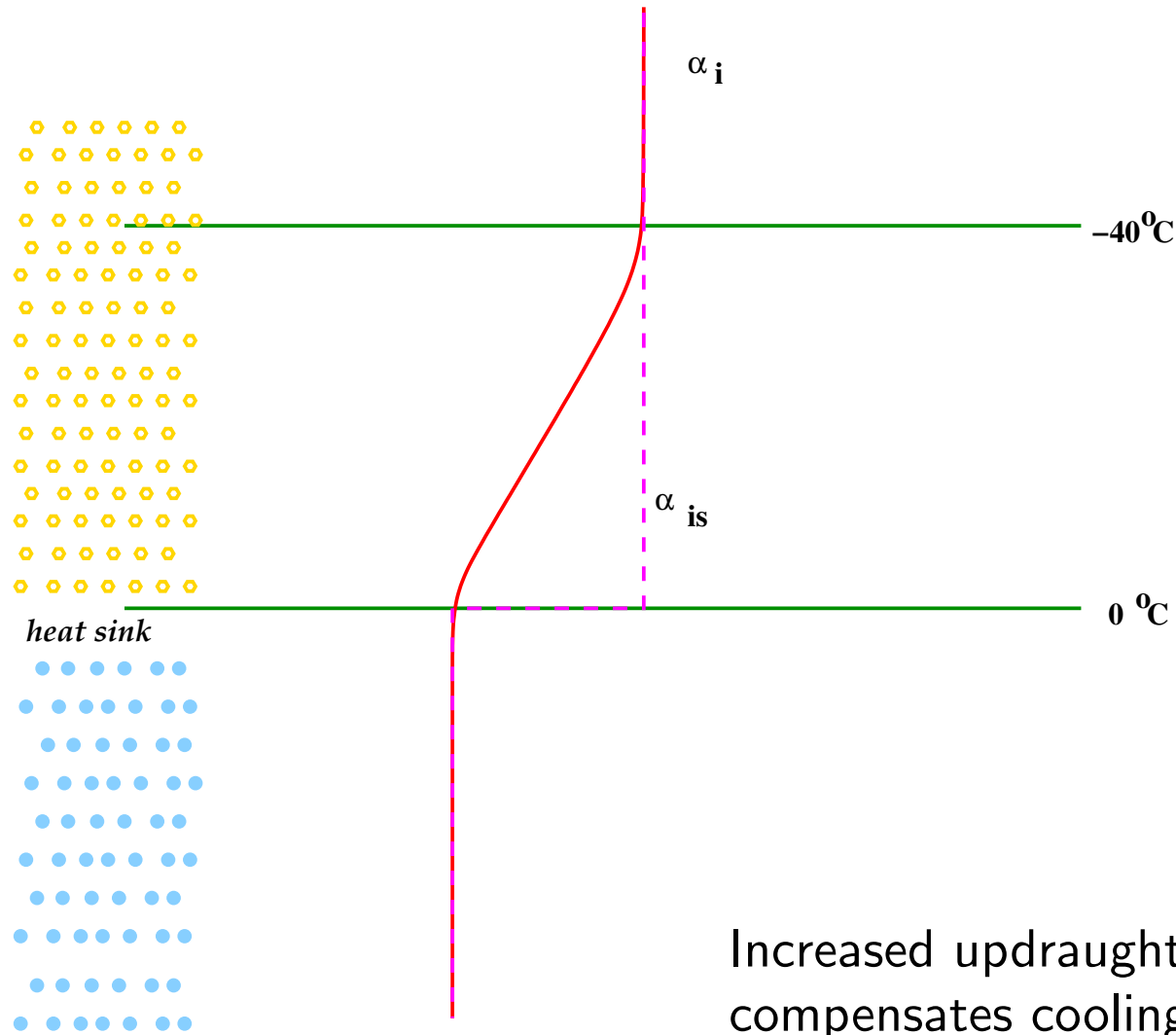

Statistic  $\alpha_i$  profile  
Newton loop does not include  $\frac{\partial \alpha_i}{\partial T}$

Use instead  $\alpha_{is}$  step profile  
and keep it constant in Newton loop

Increased updraught condensation warming  
compensates cooling by heat sink  
preventing loss of buoyancy at further time steps

# Numerical consistency

Transport :

$$J_{\psi}^u = \frac{1}{g} M_c (\bar{\psi} - \psi_u) \qquad \frac{\partial \bar{\psi}}{\partial t} = -g \frac{\partial J_{\psi}^u}{\partial p}$$

$\implies$  Implicit discretisation to compute  $J_{\psi}^u$  from  $M_c$ ,  $\Delta \psi_u$  and  $\Delta \bar{\psi}$ .



# Numerical consistency

Transport :

$$J_{\psi}^u = \frac{1}{g} M_c (\bar{\psi} - \psi_u) \qquad \frac{\partial \bar{\psi}}{\partial t} = -g \frac{\partial J_{\psi}^u}{\partial p}$$

$\implies$  Implicit discretisation to compute  $J_{\psi}^u$  from  $M_c$ ,  $\Delta\psi_u$  and  $\Delta\bar{\psi}$ .

Condensation :

$$\frac{\partial \bar{\psi}}{\partial t} = -g \frac{\partial F_{cc}}{\partial p}$$

where local condensation is proportional to  $M_c$

$\implies$  use same discretisation as transport.

# Recent results

Computational load , 46 levels, 24h run including DFI and complete I/O

Model configuration	nb points	$\Delta t$	Memory	Exec. Time
Operational Aladin Belgium 7km	240x240	600s	100	100
idem + Lopez Microphysics	240x240	600s	144	117
Alaro-0 wo 3MT, 7km	240x240	600s	155	165
ALARO-0 7km	240x240	600s	192	185
ALARO-0 4km	400x400	180s	378	500
ALARO-0 4km small domain	180x160	180s	96	154
ALARO-0 2km small domain	320x200	100s	213	862
ALARO-0 NH 2km small domain	320x200	60s	243	1851

Rem : execution time depends on

- number of points, number of steps, number of model variables
- time spent in parametrisation following atmospheric situation
- initialisation steps
- i/o which increases when saving bigger files.

# Examples of prediction charts : thunderstorms, 10/09/2005

# Examples of prediction charts : thunderstorms, 10/09/2005

tA7vl : 2005/9/10 z12:0 +4h

tA4vl : 2005/9/10 z12:0 +4h

tA2vl : 2005/9/10 z12:0 +4h

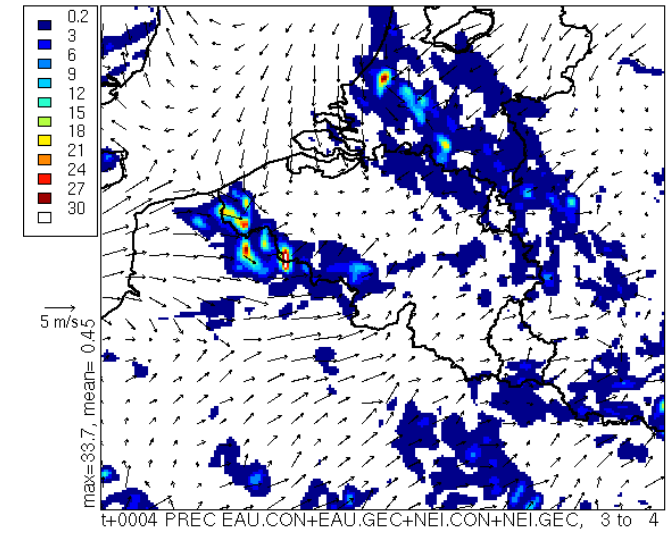
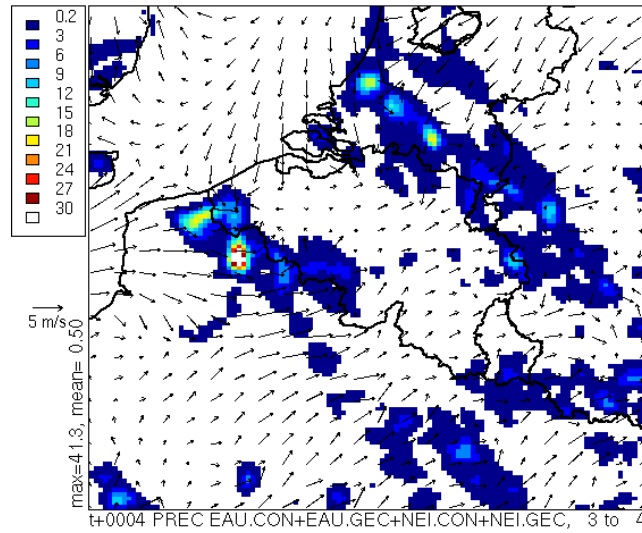
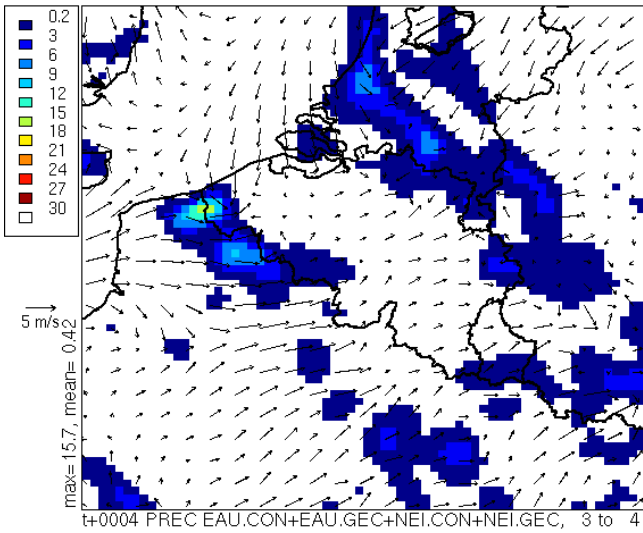

tA2vl\_nh : 2005/9/10 z12:0 +4h

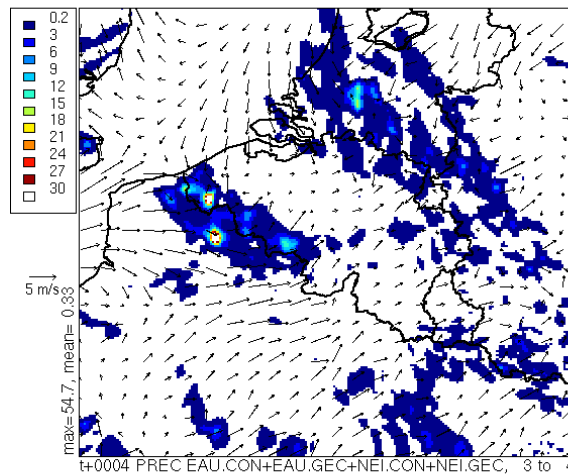

1h radar precipitation accumulation (mm) Starting at 10/09/2005 15 UT 12 /12 RMI - Belgium

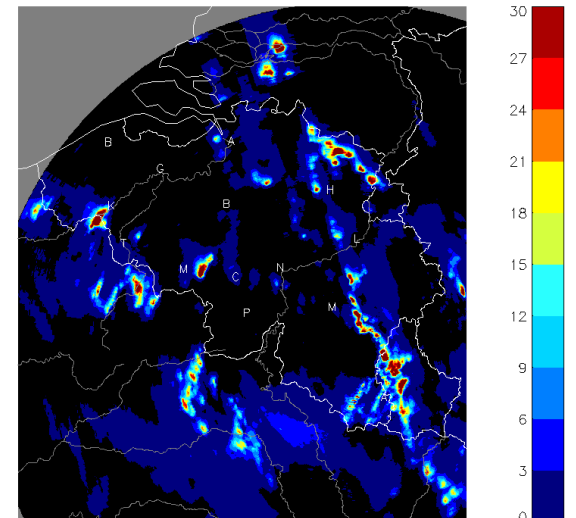

# Examples of prediction charts : thunderstorms, 10/09/2005

tA7vl : 2005/9/10 z12:0 +5h

tA4vl : 2005/9/10 z12:0 +5h

tA2vl : 2005/9/10 z12:0 +5h

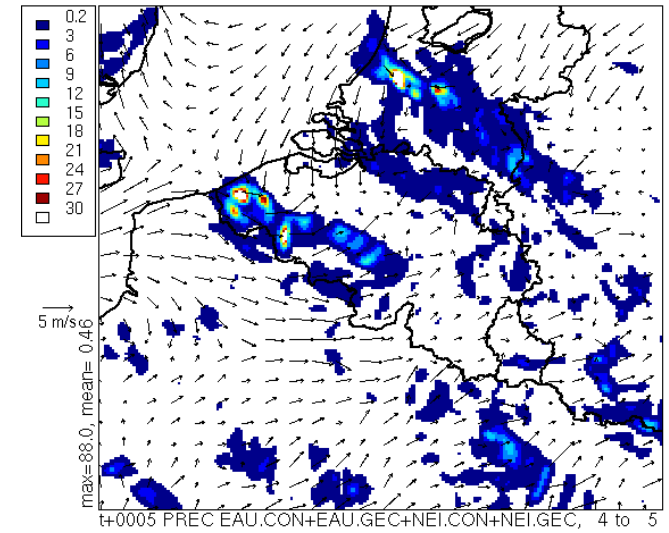
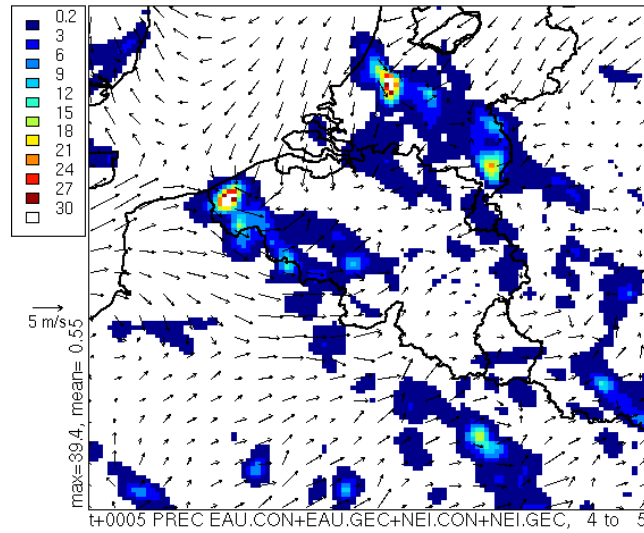
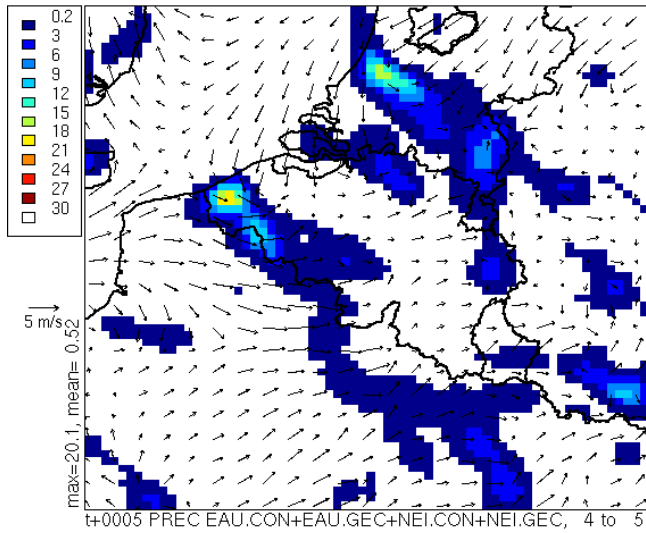

tA2vl\_nh : 2005/9/10 z12:0 +5h

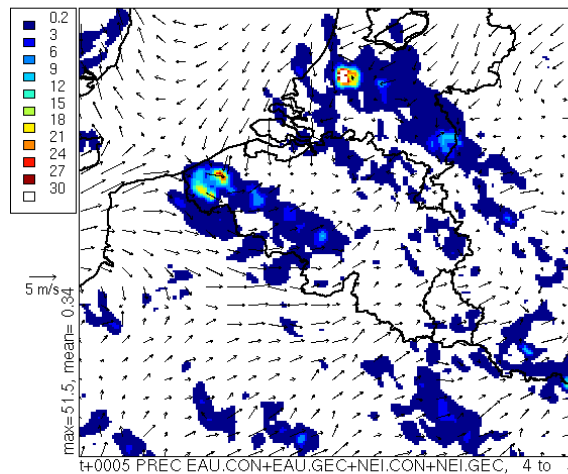

1h radar precipitation accumulation (mm) Starting at 10/09/2005 16 UT 12 /12 Radar Wideumont RMI - Belgium

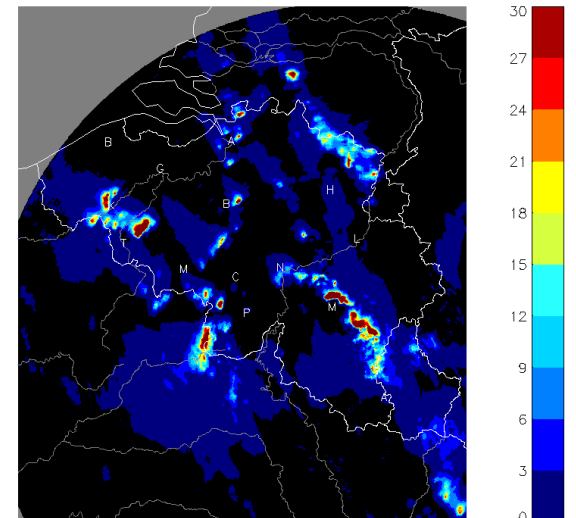

# Examples of prediction charts : thunderstorms, 10/09/2005

tA7vl : 2005/9/10 z12:0 +6h

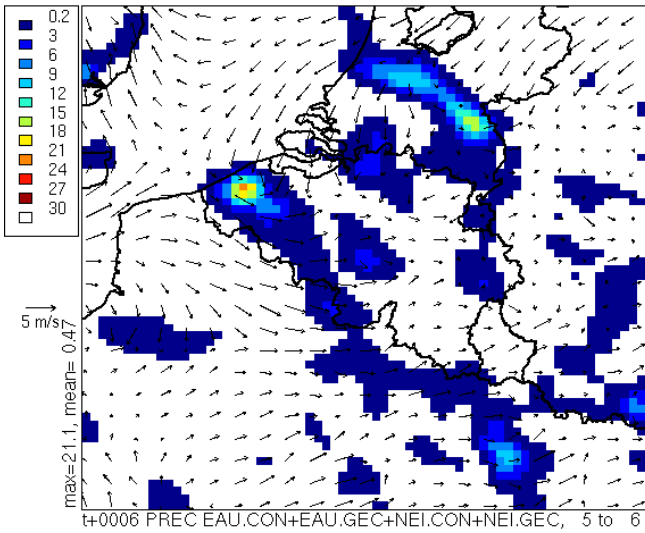

tA4vl : 2005/9/10 z12:0 +6h

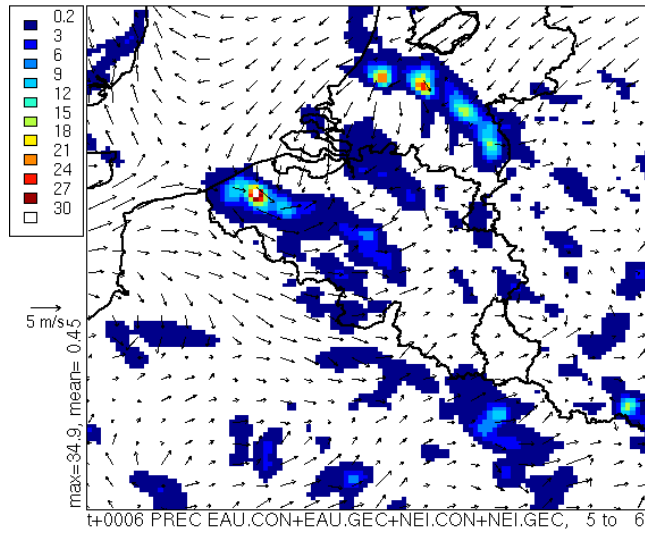

tA2vl : 2005/9/10 z12:0 +6h

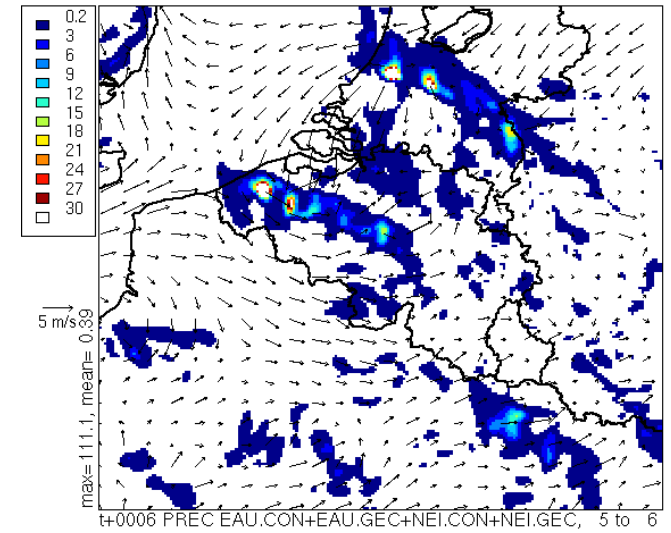

tA2vl\_nh : 2005/9/10 z12:0 +6h

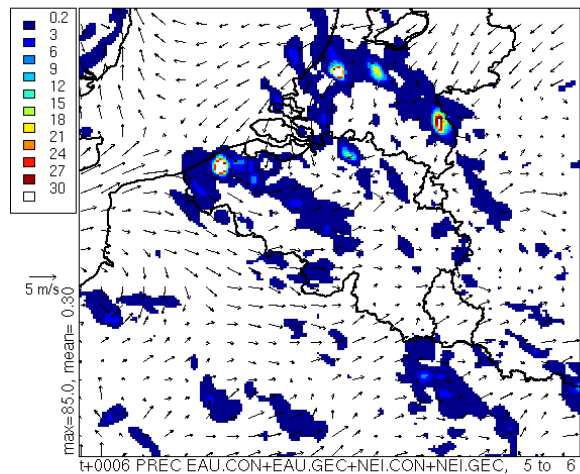

1h radar precipitation accumulation (mm) Starting at 10/09/2005 17 UT 12 /12 Radar Wideumont RMI - Belgium

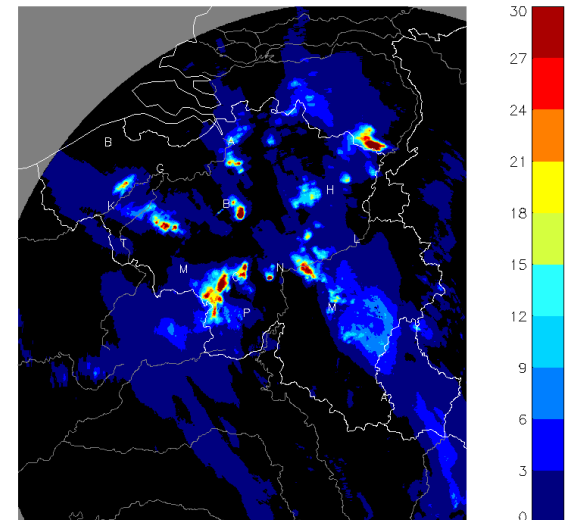

# Examples of prediction charts : thunderstorms, 10/09/2005

tA7vl : 2005/9/10 z12:0 +7h

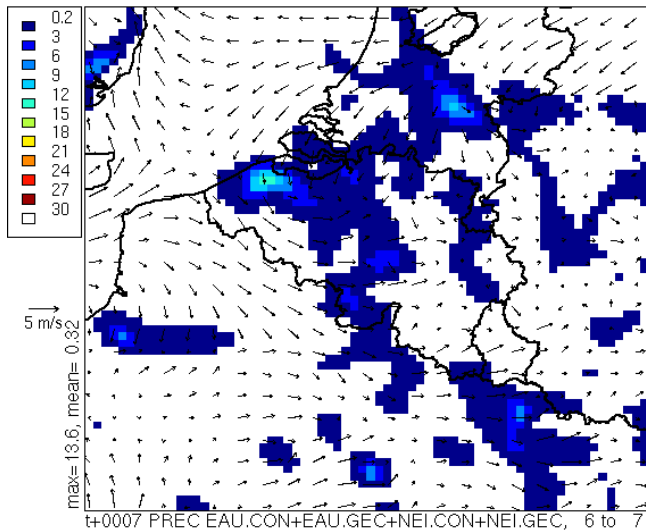

tA4vl : 2005/9/10 z12:0 +7h

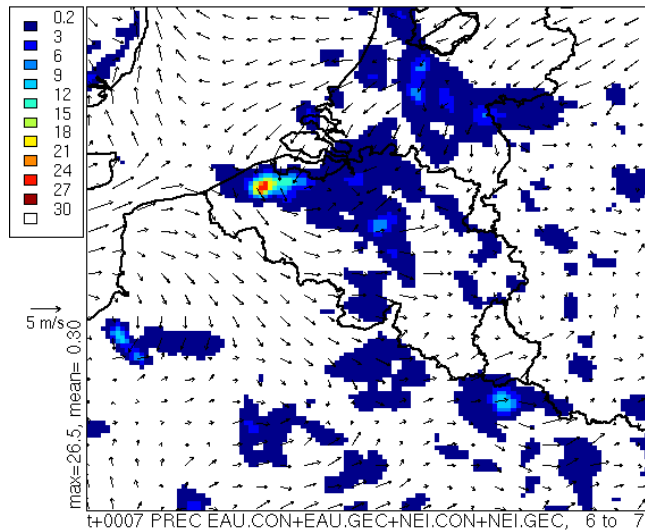

tA2vl : 2005/9/10 z12:0 +7h

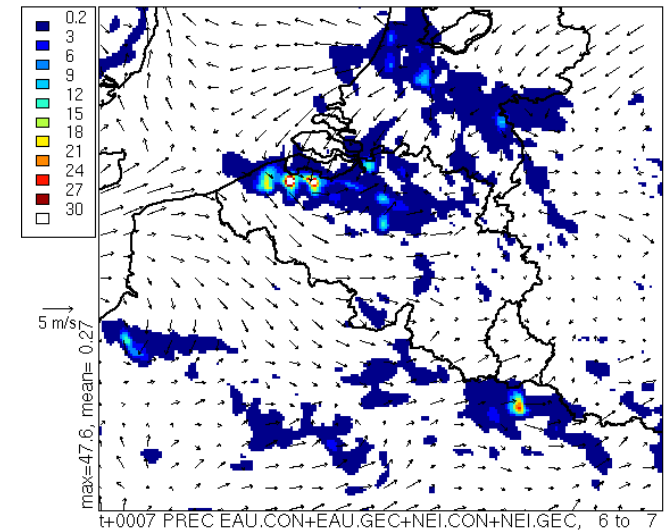

tA2vl\_nh : 2005/9/10 z12:0 +7h

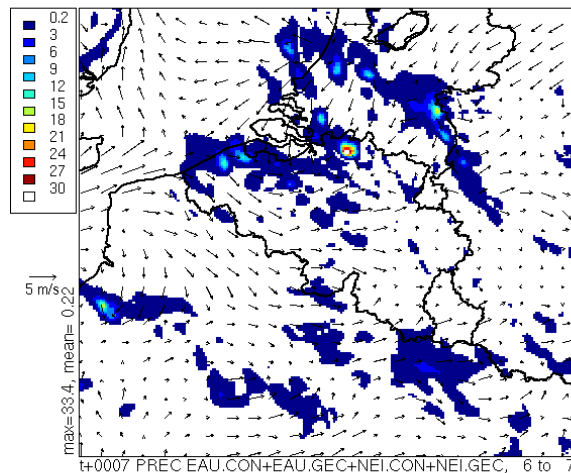

1h radar precipitation accumulation (mm) Starting at 10/09/2005 18 UT 12 /12 Radar Wideumont RMI - Belgium

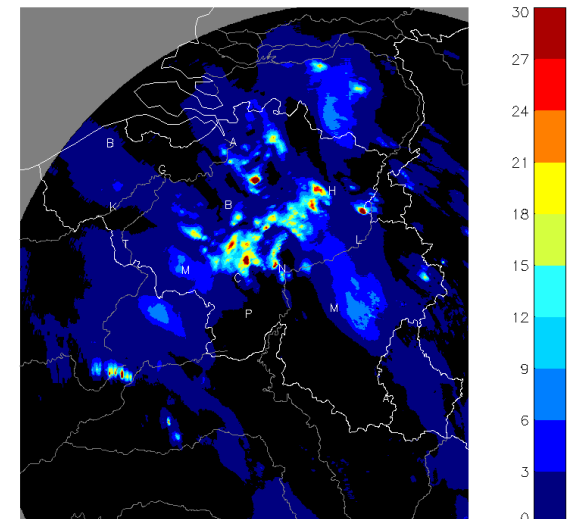



# Examples of prediction charts : thunderstorms, 10/09/2005

tA7vl : 2005/9/10 z12:0 +8h

tA4vl : 2005/9/10 z12:0 +8h

tA2vl : 2005/9/10 z12:0 +8h

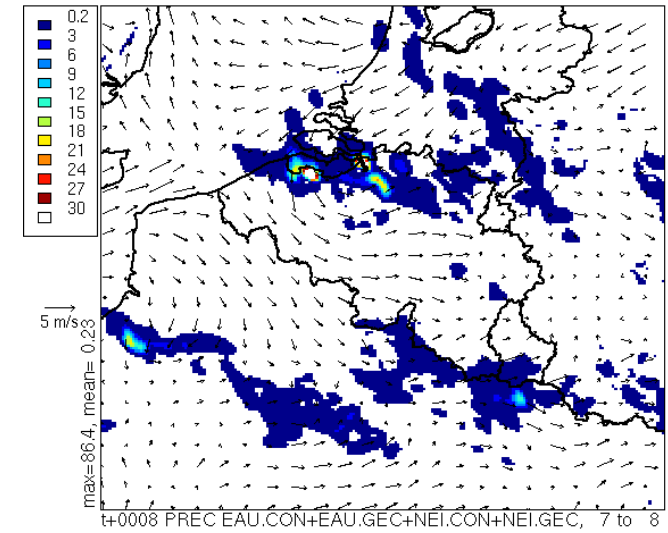
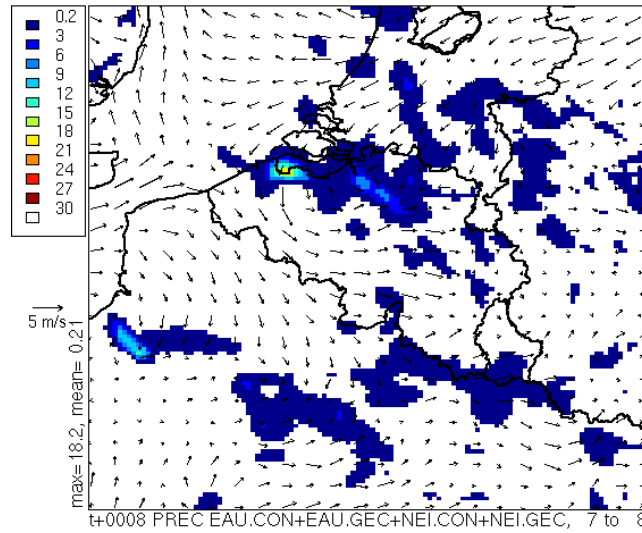
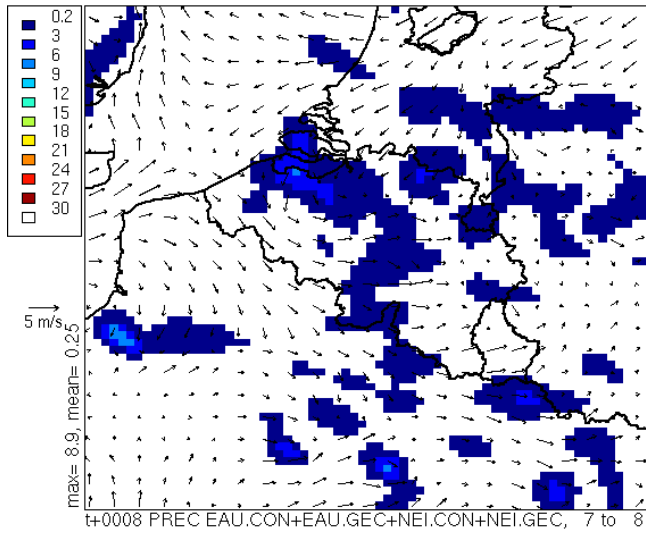

tA2vl\_nh : 2005/9/10 z12:0 +8h

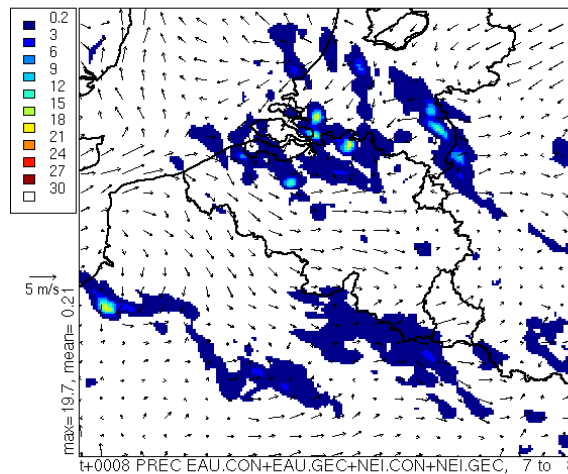

1h radar precipitation accumulation (mm) Starting at 10/09/2005 19 UT 12 /12 Radar Wideumont RMI - Belgium

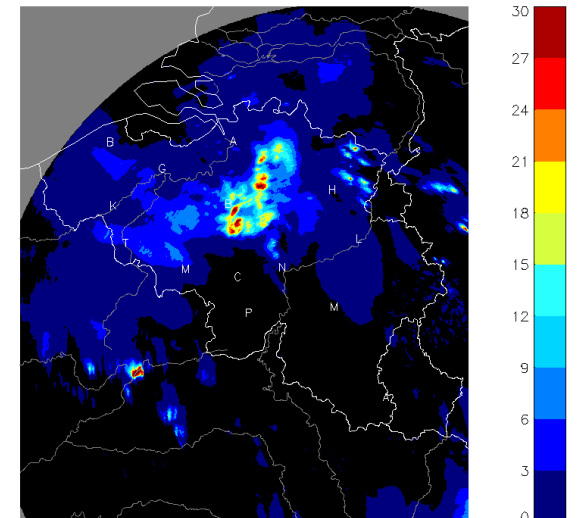



# Examples of prediction charts : thunderstorms, 10/09/2005

tA7vl : 2005/9/10 z12:0 +9h

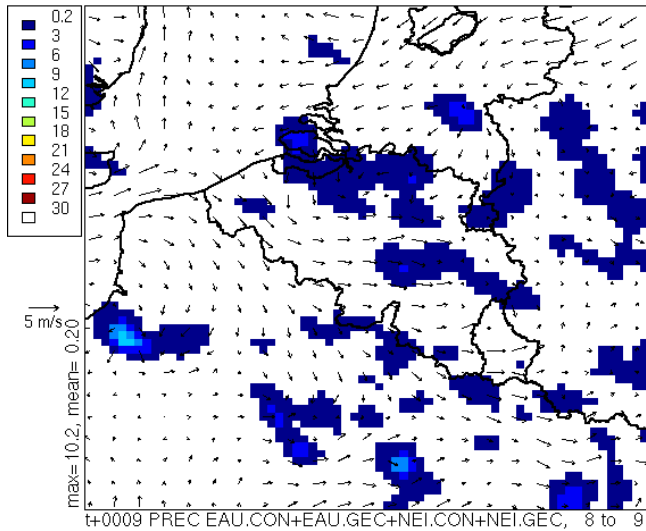

tA4vl : 2005/9/10 z12:0 +9h

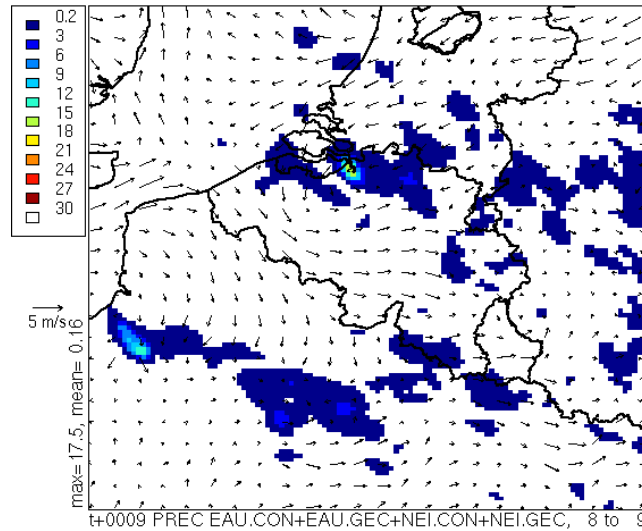

tA2vl : 2005/9/10 z12:0 +9h

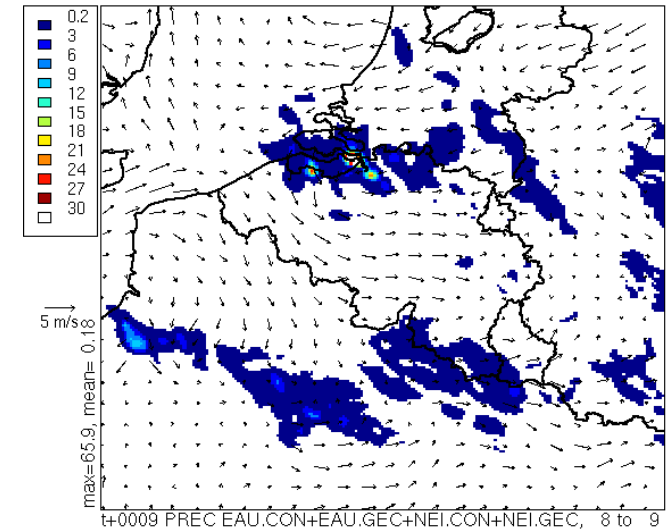

tA2vl\_nh : 2005/9/10 z12:0 +9h

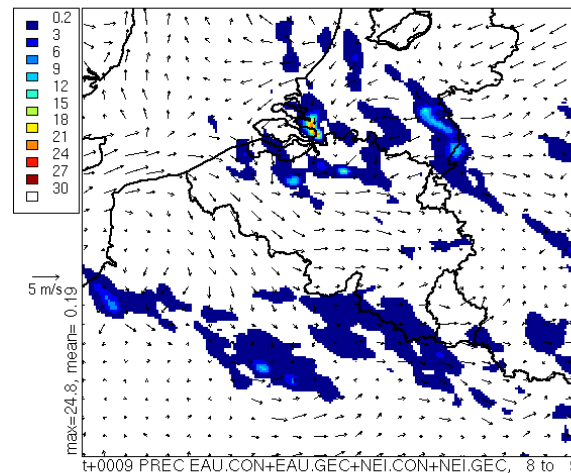

1h radar precipitation accumulation (mm) Starting at 10/09/2005 20 UT 12 / 12 Radar Wideumont RMI - Belgium

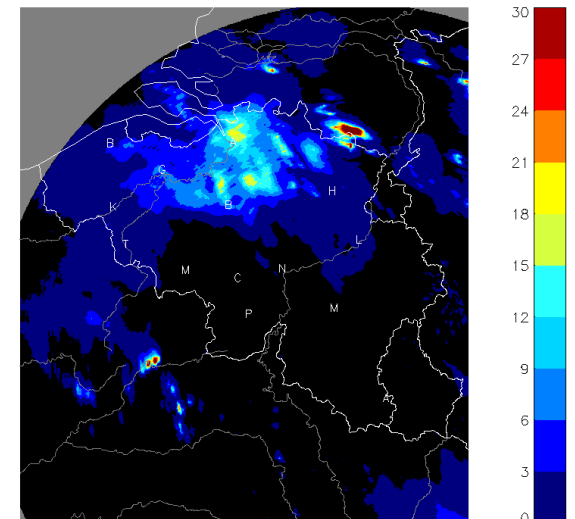

# Examples of prediction charts : thunderstorms, 10/09/2005

tA7vl : 2005/9/10 z12:0 +10h

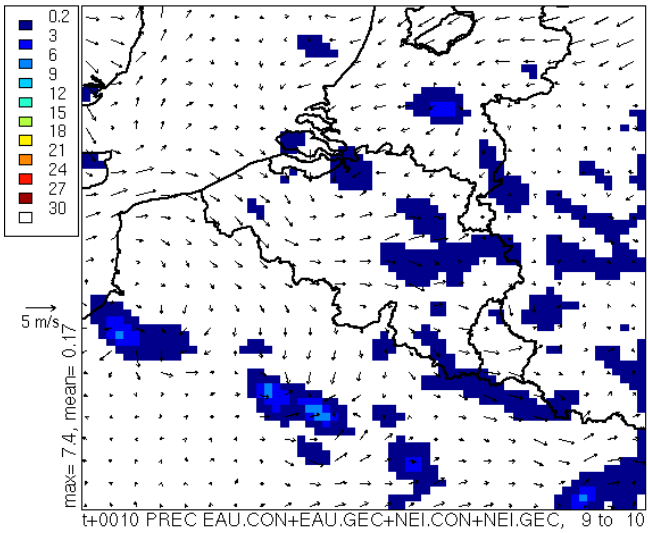

tA4vl : 2005/9/10 z12:0 +10h

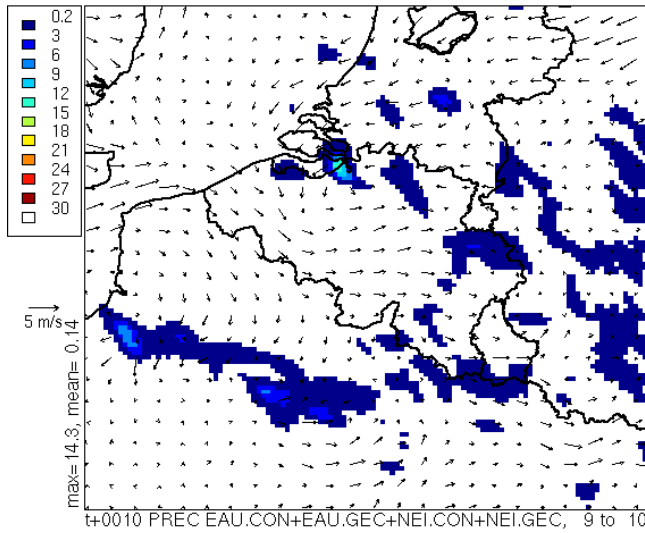

tA2vl : 2005/9/10 z12:0 +10h

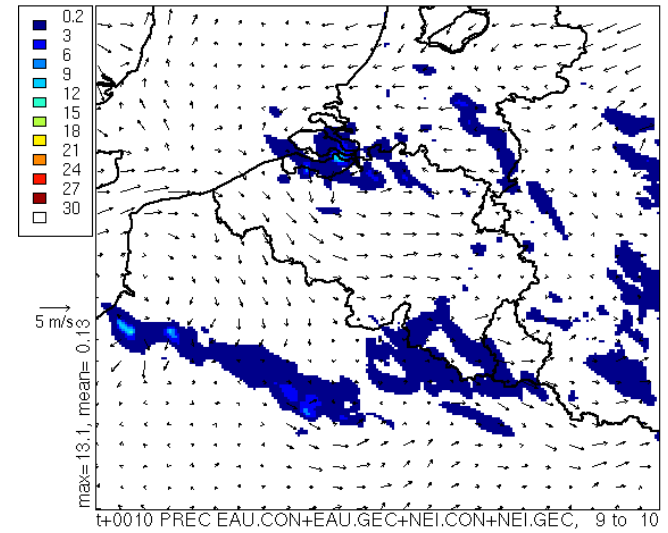

tA2vl\_nh : 2005/9/10 z12:0 +10h

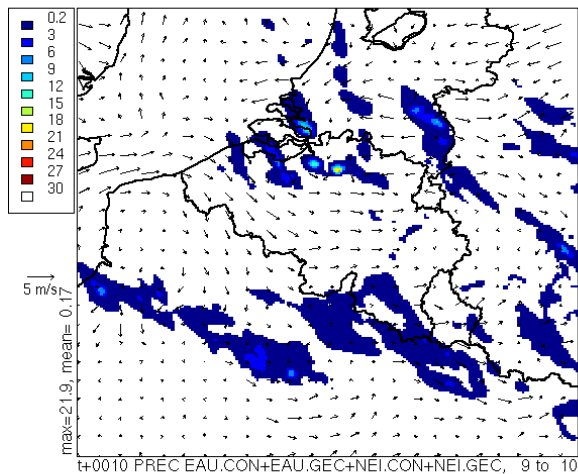

1h radar precipitation accumulation (mm) Starting at 10/09/2005 21 UT 12 /12 Radar Wideumont RMI - Belgium

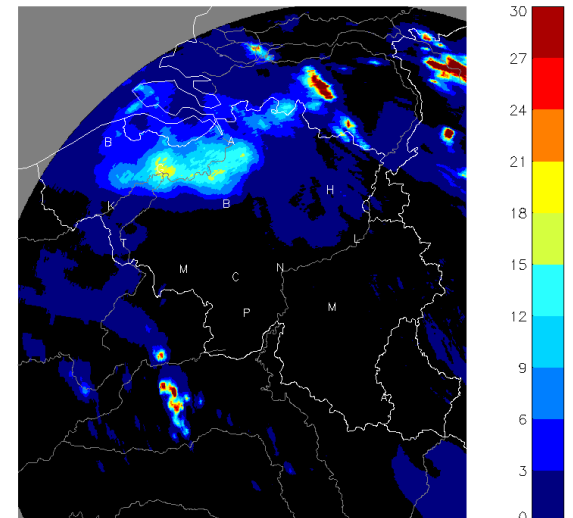

# Examples of prediction charts : thunderstorms, 10/09/2005

tA7vl : 2005/9/10 z12:0 +11h

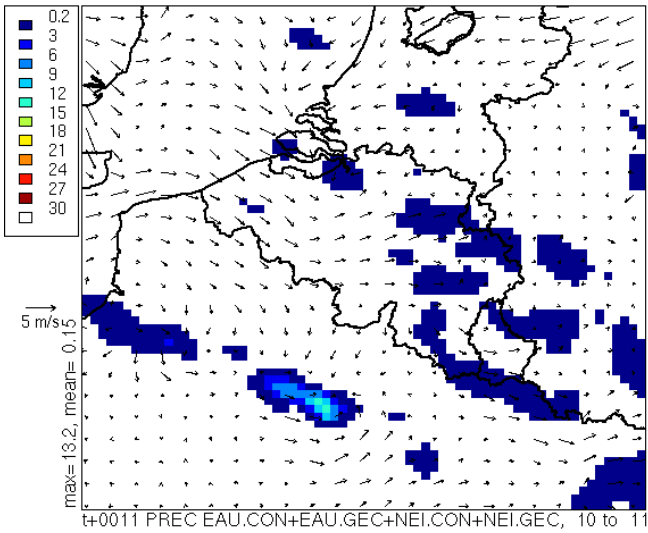

tA4vl : 2005/9/10 z12:0 +11h

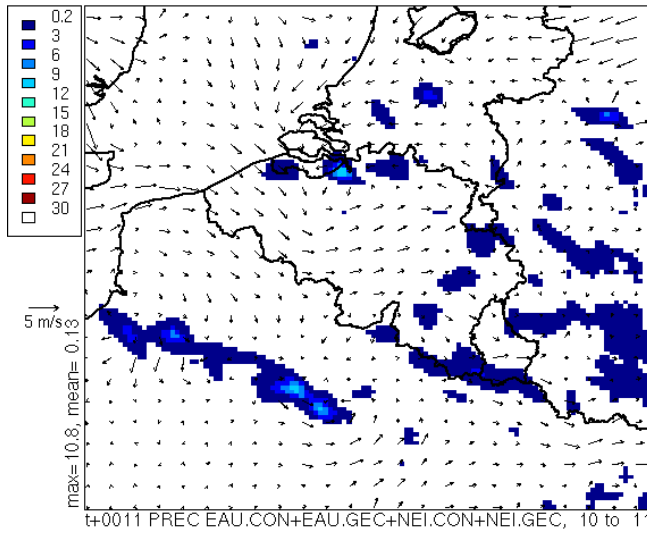

tA2vl : 2005/9/10 z12:0 +11h

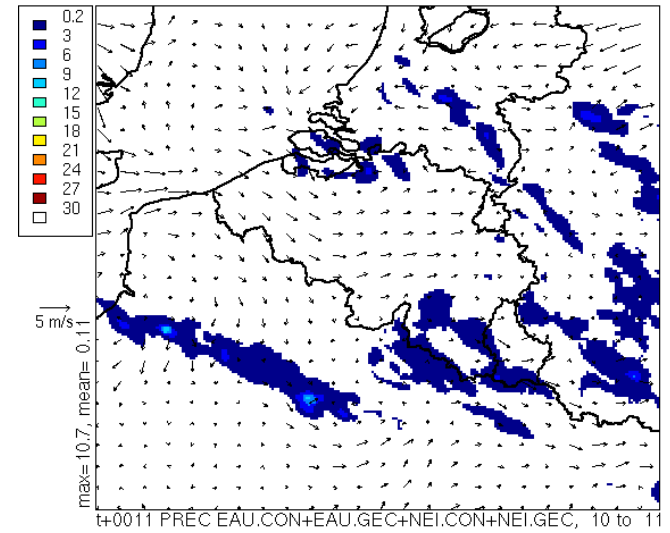

tA2vl\_nh : 2005/9/10 z12:0 +11h

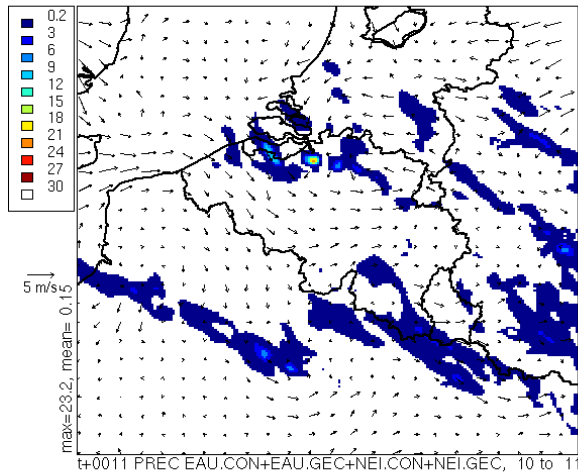

1h radar precipitation accumulation (mm) Starting at 10/09/2005 22 UT 12 /12 RMI - Belgium

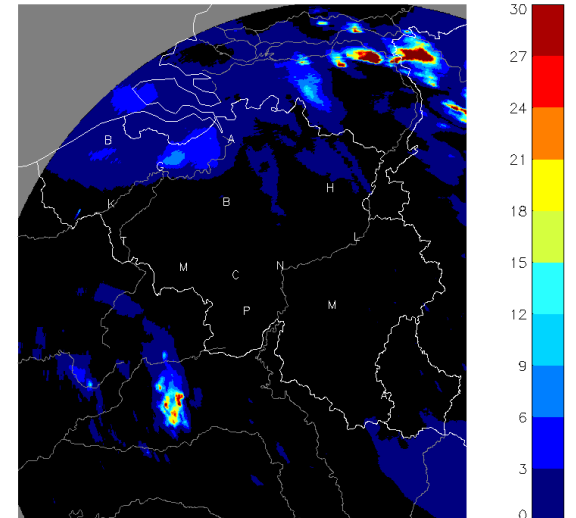

# Examples of prediction charts : thunderstorms, 10/09/2005

tA7vl : 2005/9/10 z12:0 +12h

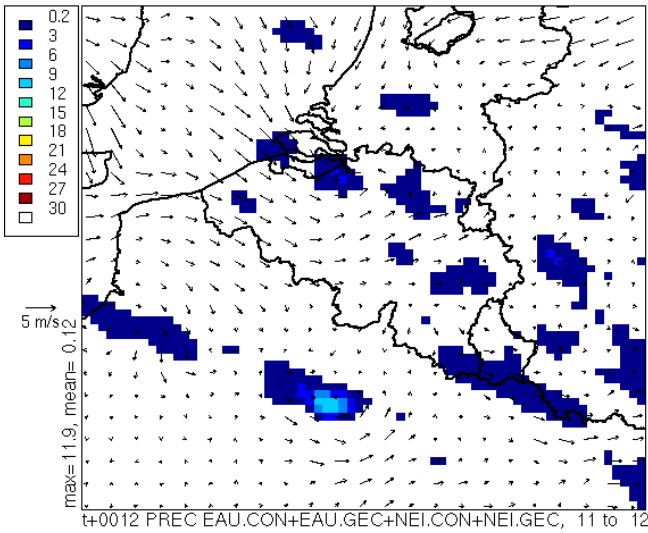

tA4vl : 2005/9/10 z12:0 +12h

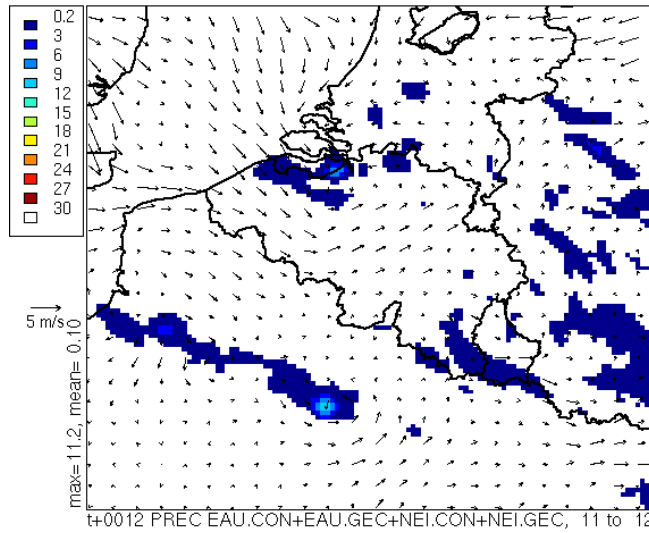

tA2vl : 2005/9/10 z12:0 +12h

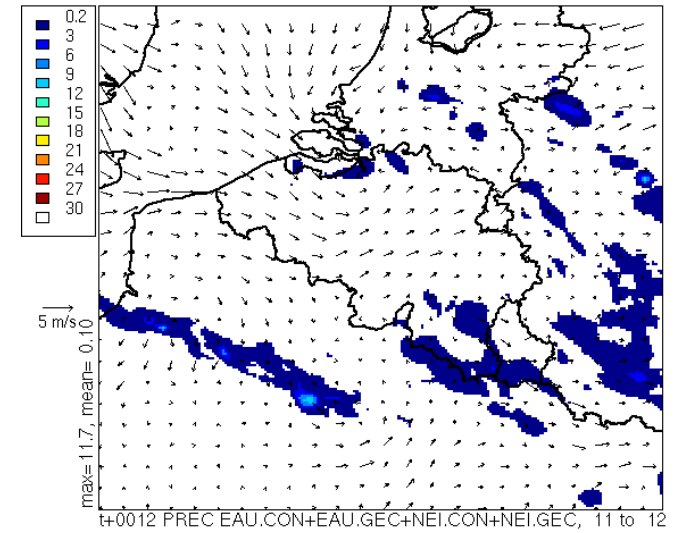

tA2vl\_nh : 2005/9/10 z12:0 +12h

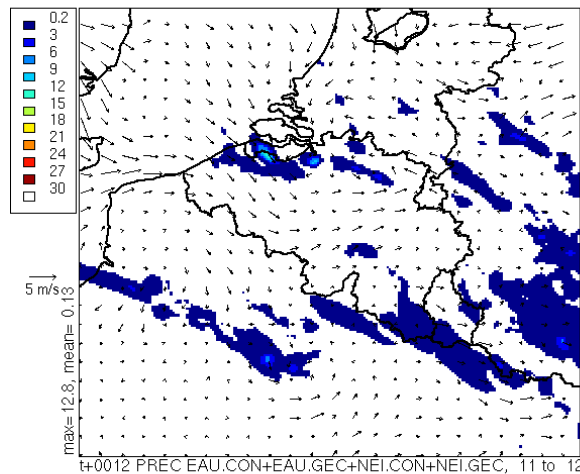

1h radar precipitation accumulation (mm) Starting at 10/09/2005 23 UT 12 /12 RMI - Belgium

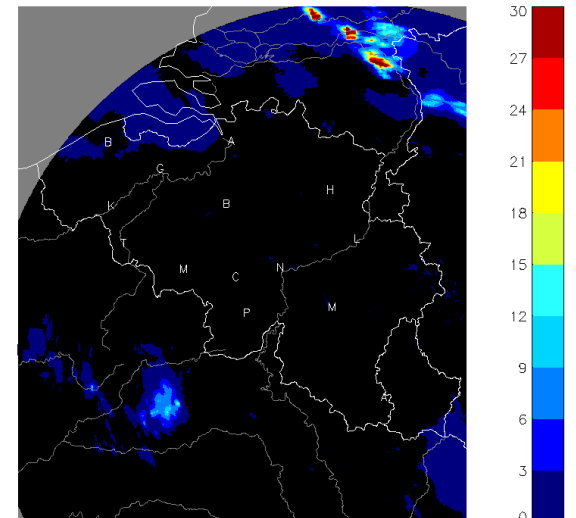

# DDH : Vertical profile of tendency components

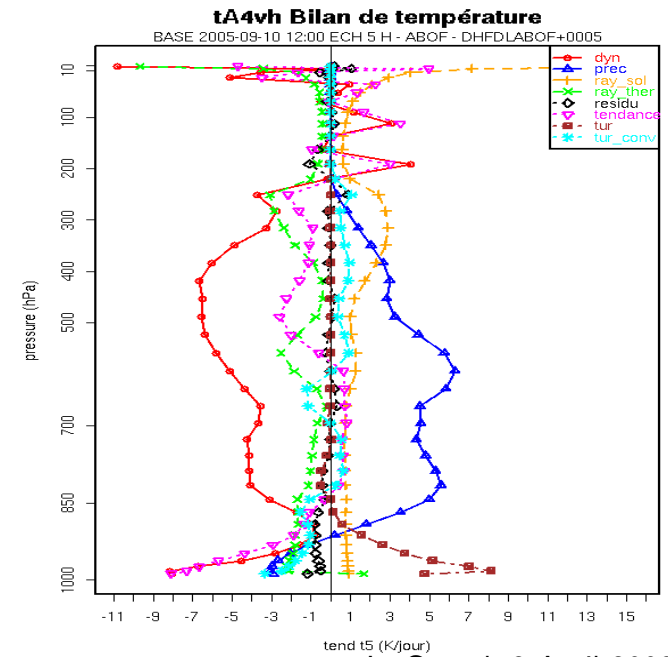
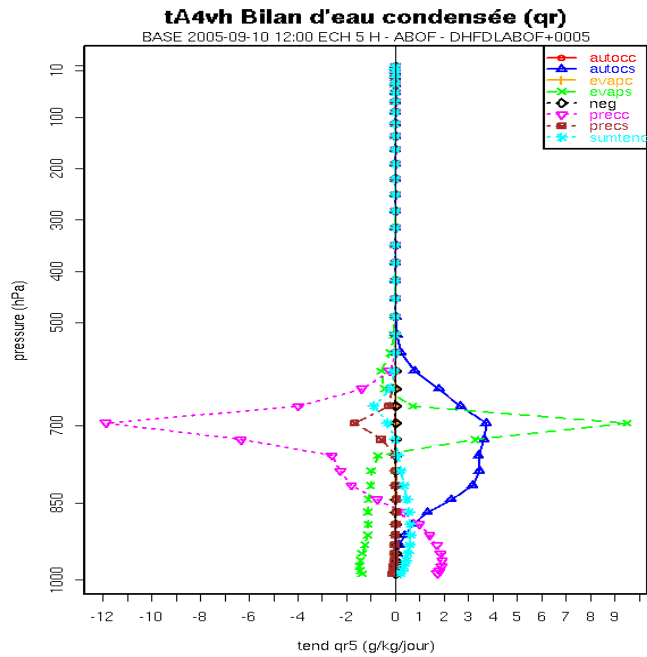
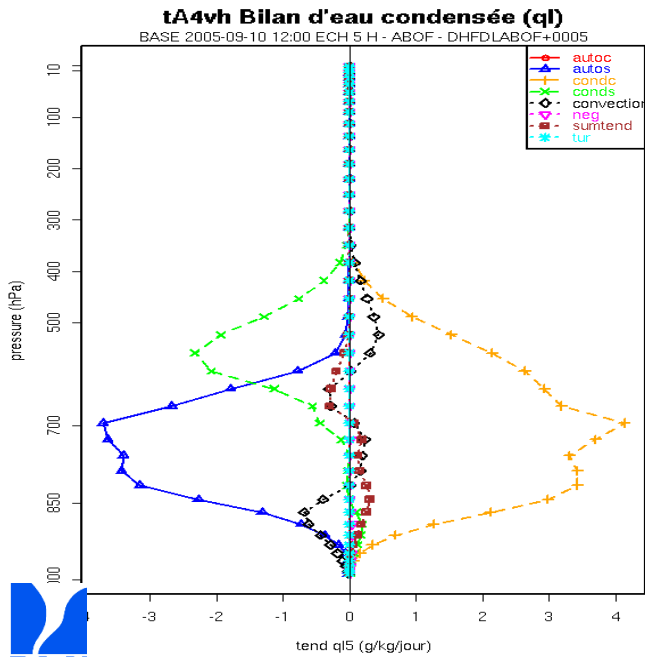
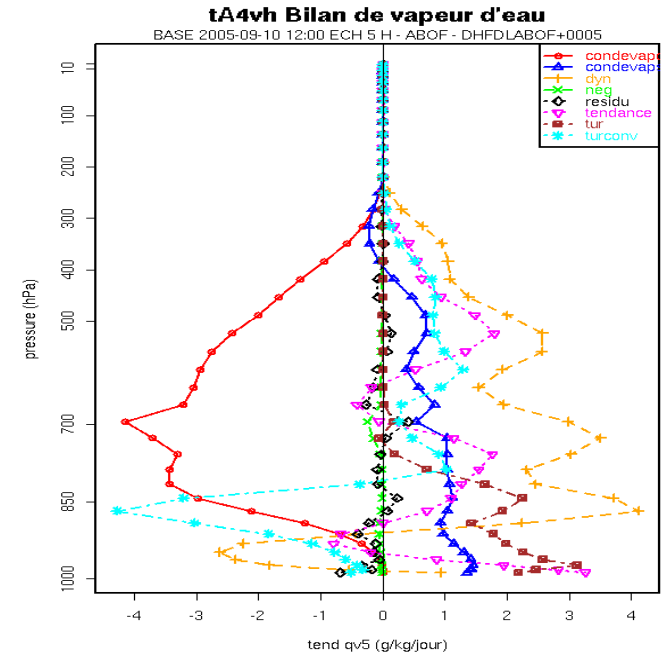
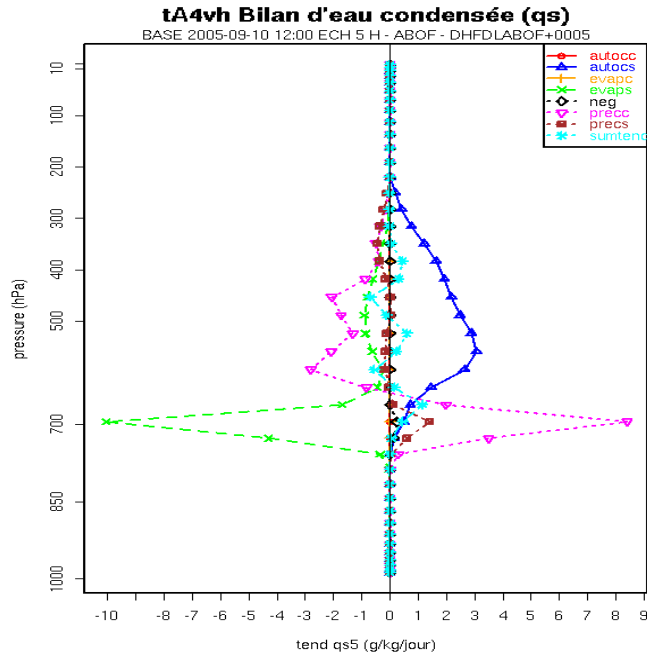
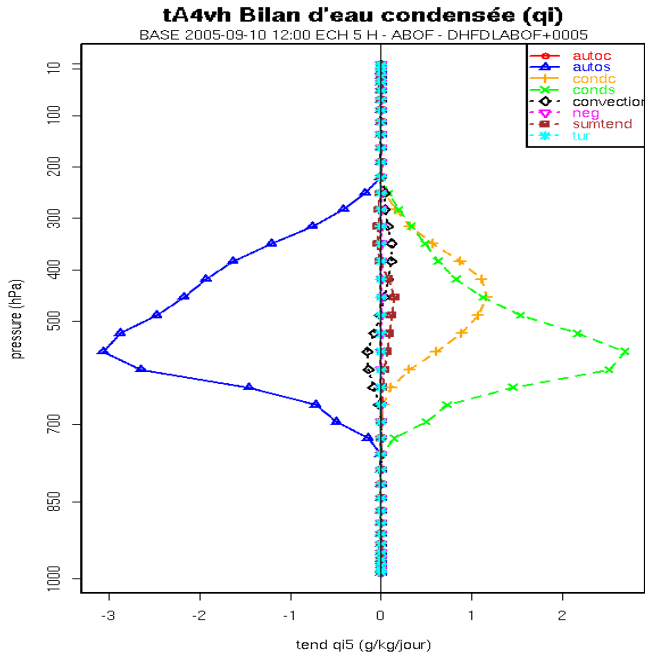

# Examples of prediction charts : downpours, 21/03/2008



# Examples of prediction charts : downpours, 21/03/2008

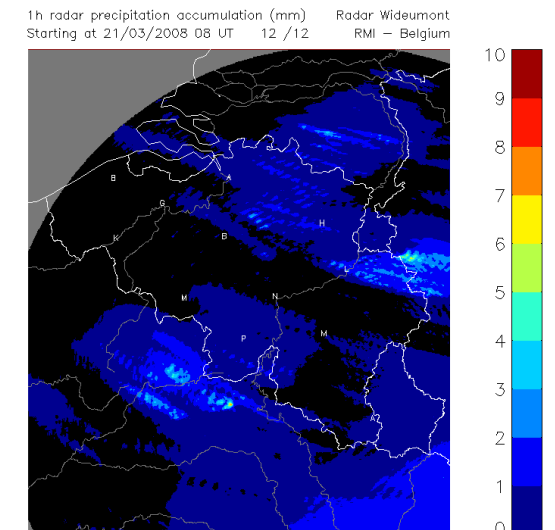
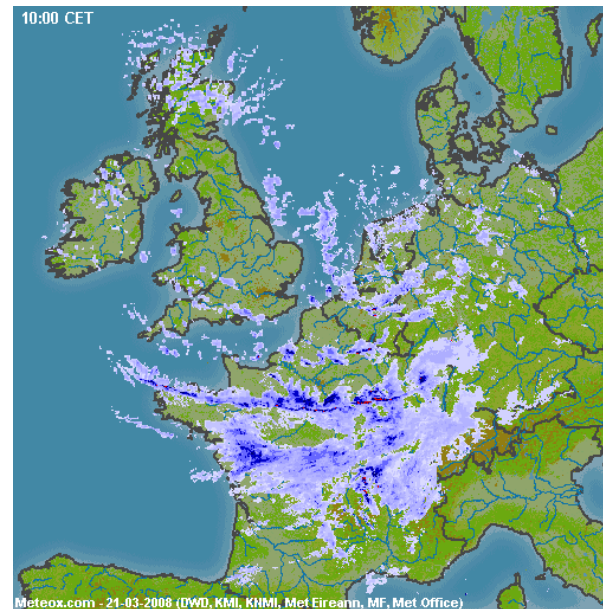
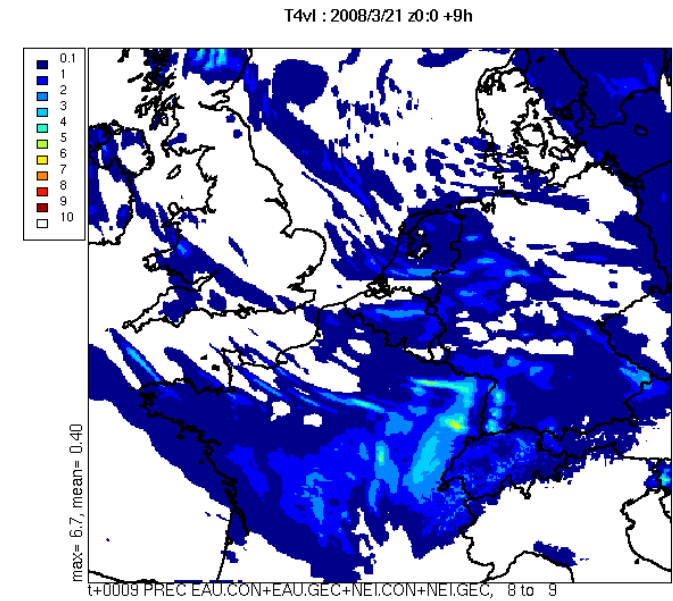
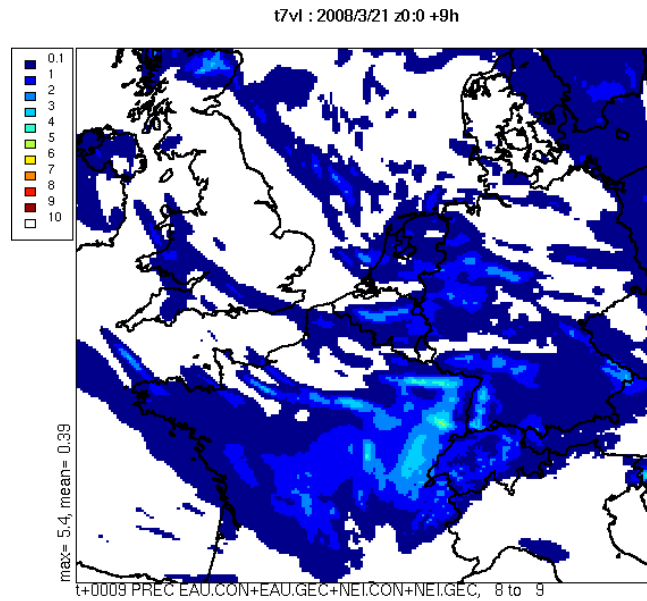
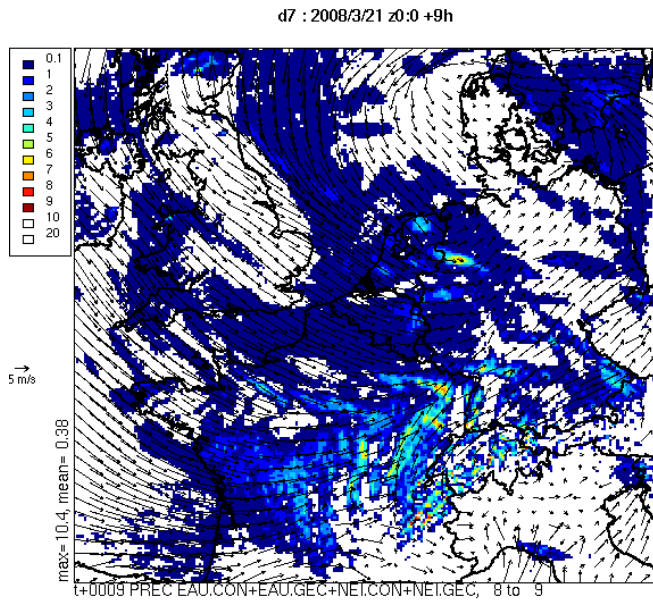

# Examples of prediction charts : downpours, 21/03/2008

d7 : 2008/3/21 z0:0 +10h

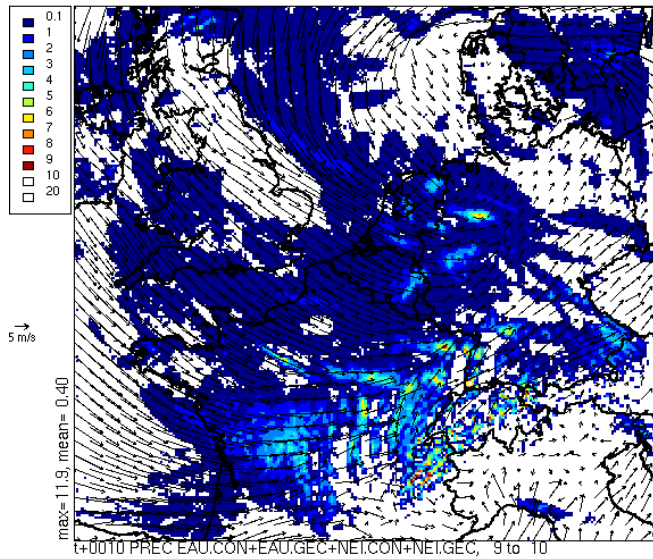

t7v1 : 2008/3/21 z0:0 +10h

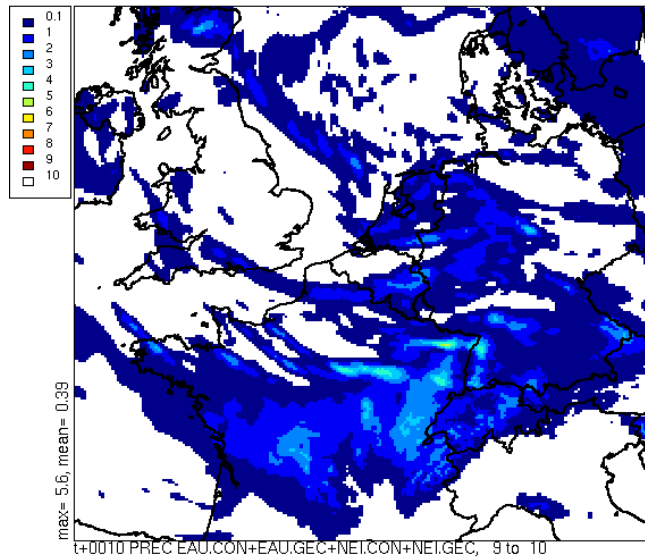

T4v1 : 2008/3/21 z0:0 +10h

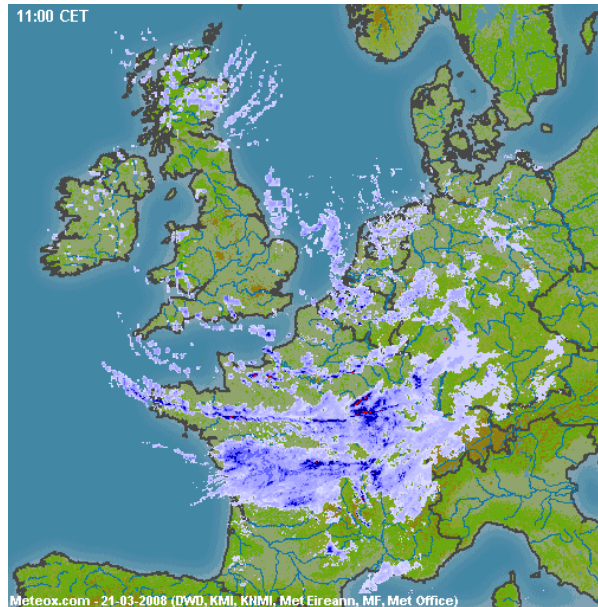
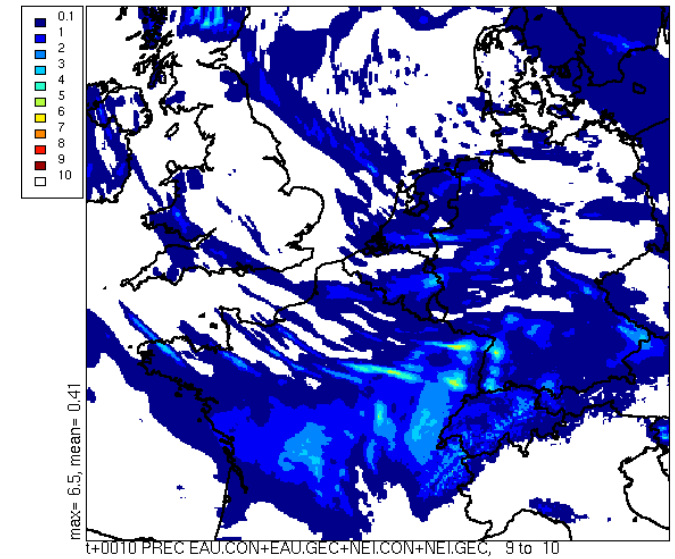

1h radar precipitation accumulation (mm) Starting at 21/03/2008 09 UT 12 /12 Radar Wideumont RMI - Belgium

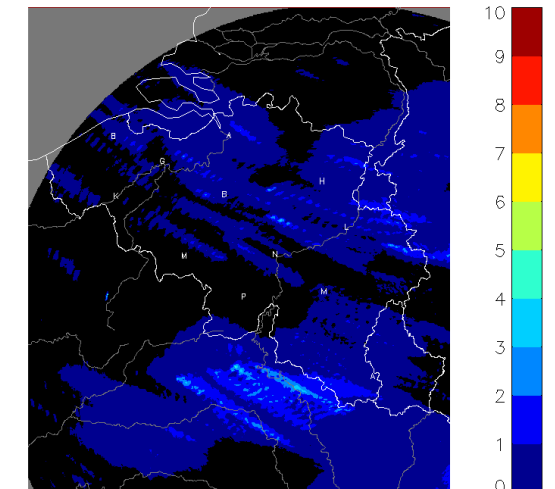



# Examples of prediction charts : downpours, 21/03/2008

d7 : 2008/3/21 z0:0 +11h

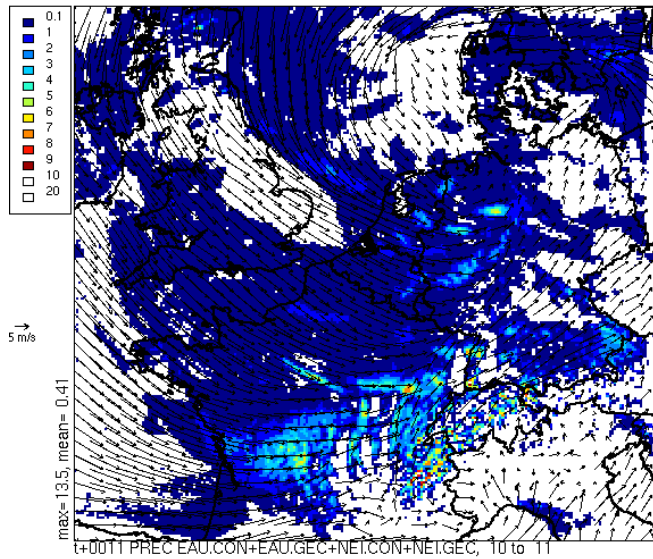

t7vl : 2008/3/21 z0:0 +11h

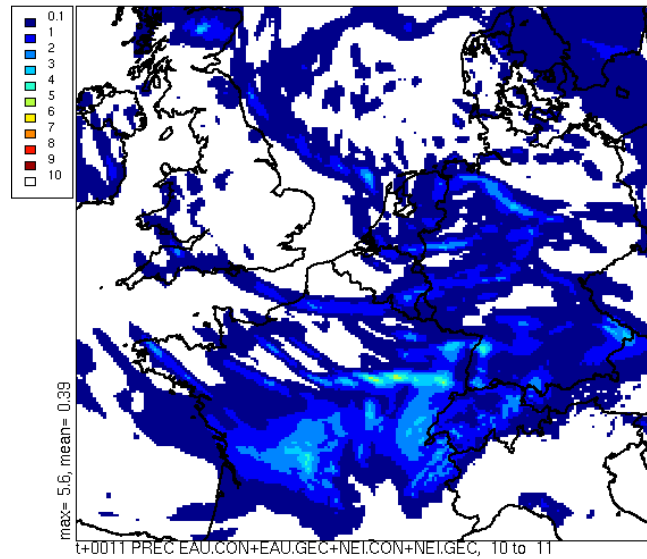

T4vl : 2008/3/21 z0:0 +11h

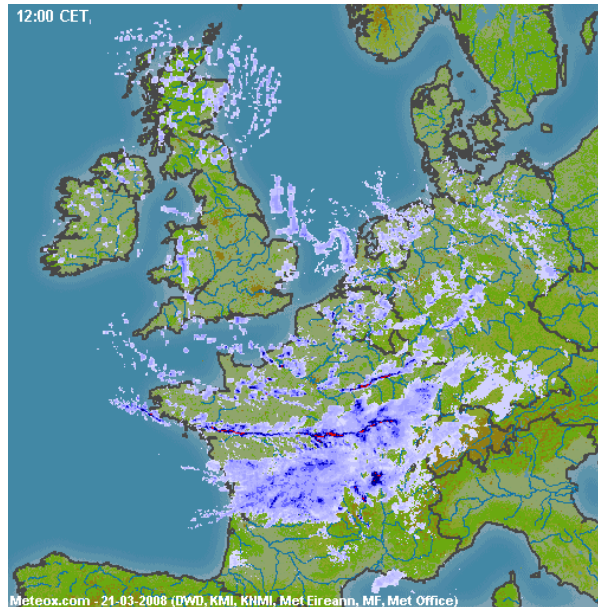
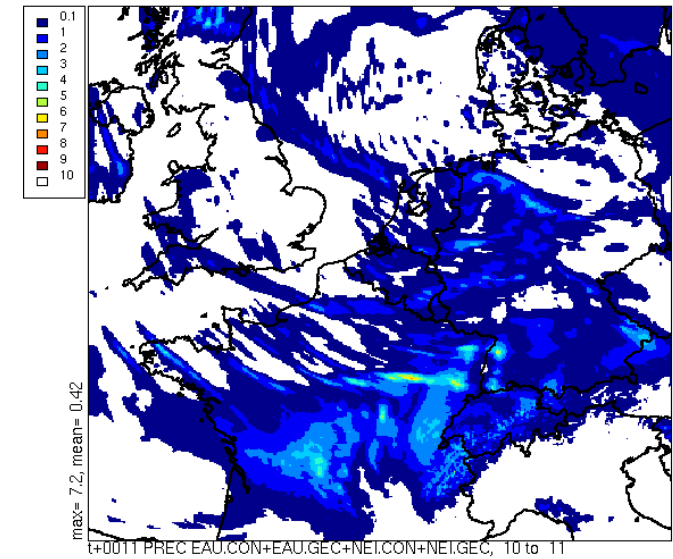

1h radar precipitation accumulation (mm) Starting at 21/03/2008 10 UT 12 /12

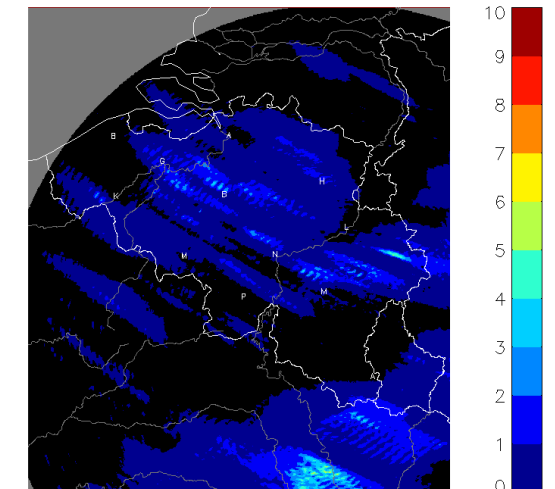

# Examples of prediction charts : downpours, 21/03/2008

d7 : 2008/3/21 z0:0 +12h

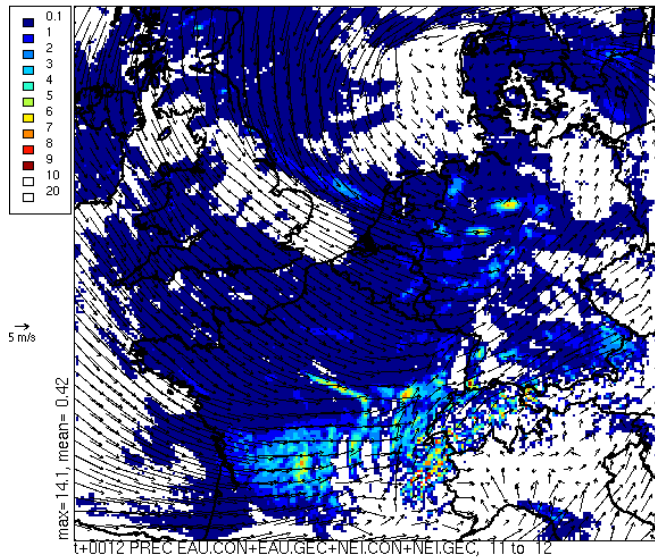

t7vl : 2008/3/21 z0:0 +12h

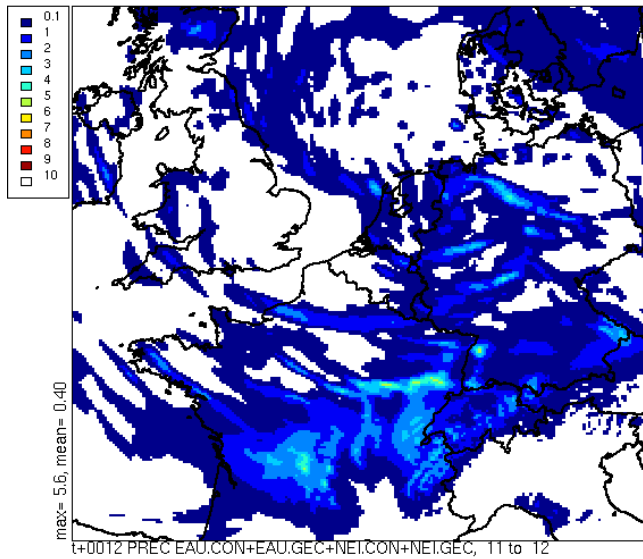

T4vl : 2008/3/21 z0:0 +12h

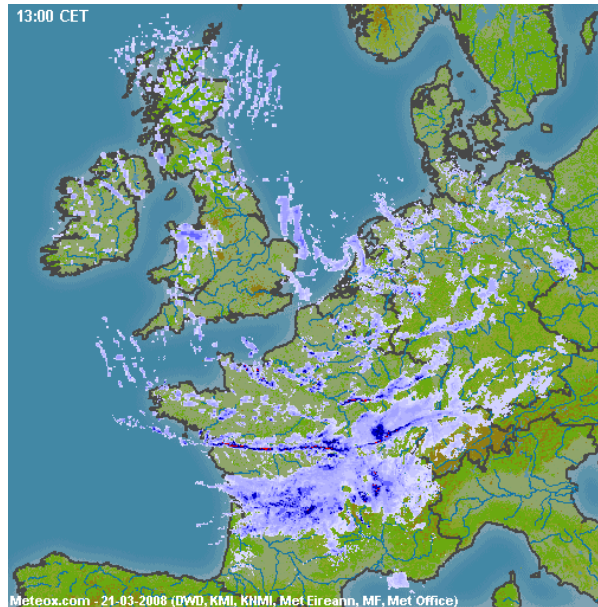
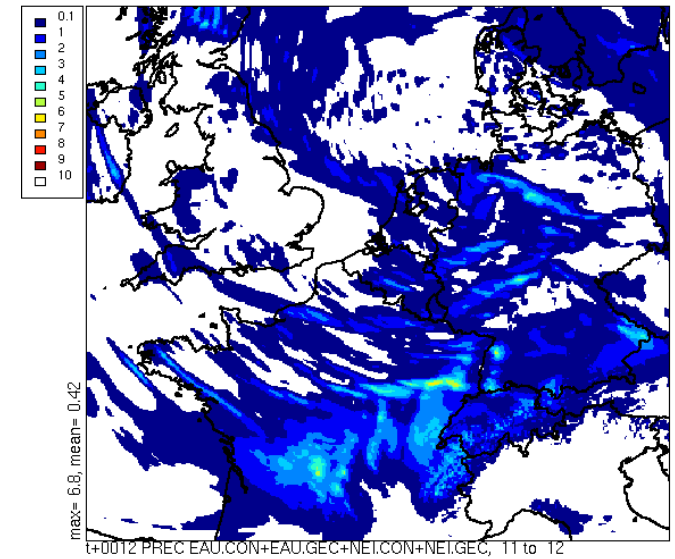

1h radar precipitation accumulation (mm) Starting at 21/03/2008 11 UT 12 /12 Radar Wideumont RMI - Belgium

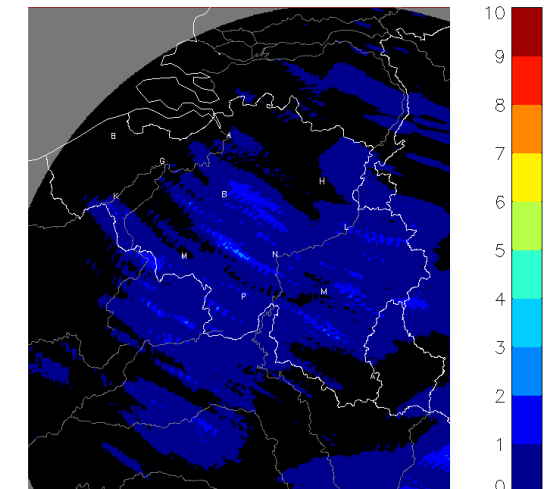



# Examples of prediction charts : downpours, 21/03/2008

d7 : 2008/3/21 z0:0 +13h

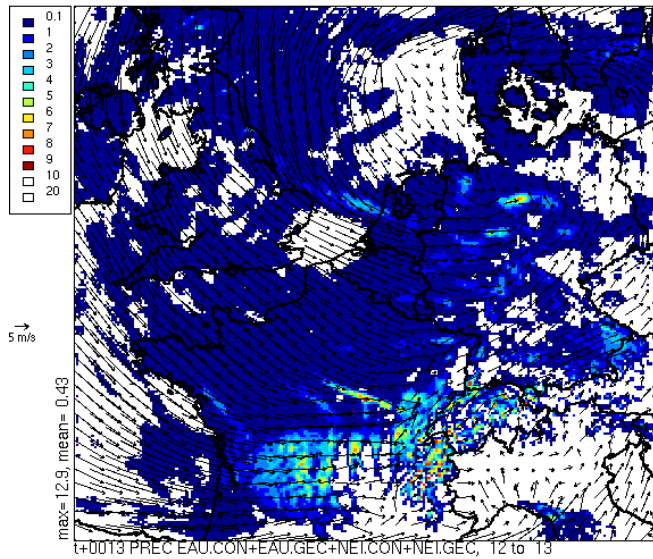

t7vl : 2008/3/21 z0:0 +13h

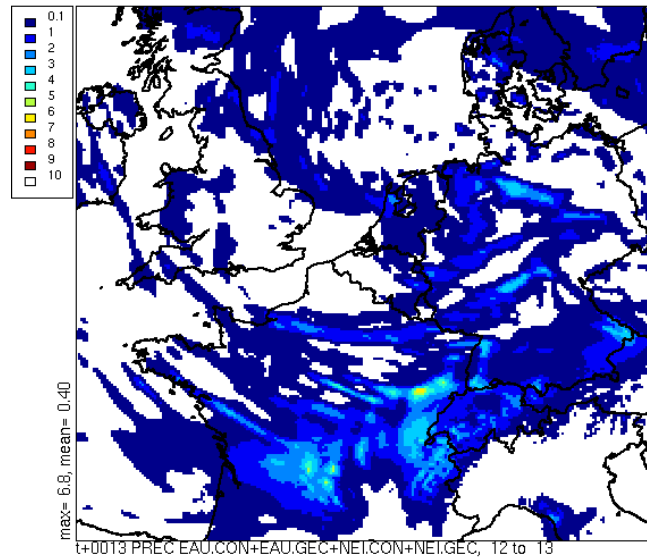

T4vl : 2008/3/21 z0:0 +13h

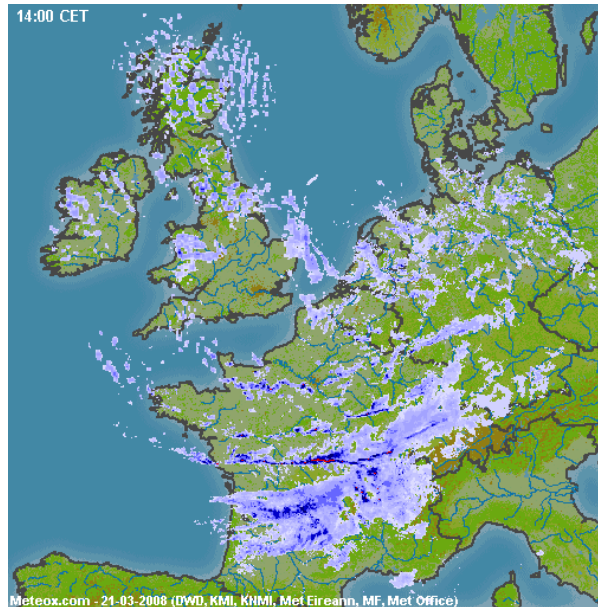
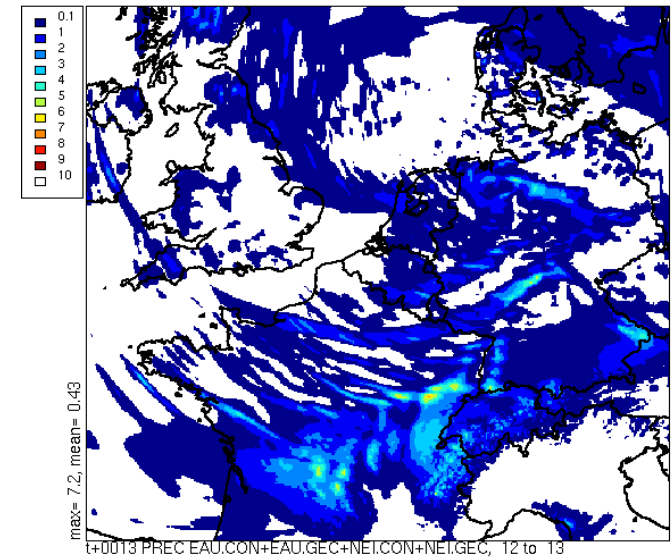

1h radar precipitation accumulation (mm) Starting at 21/03/2008 12 UT 12 /12 Radar Wideumont RMI - Belgium

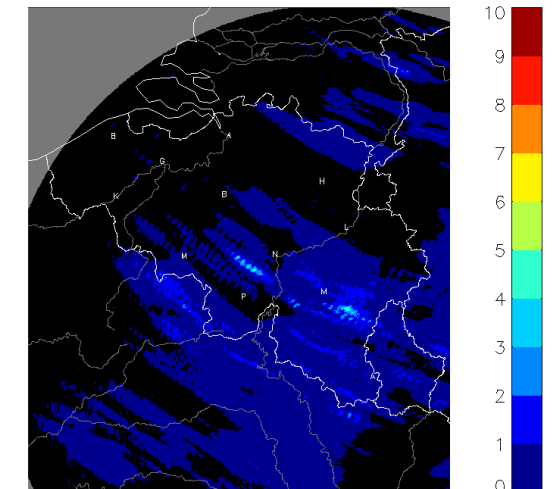

# Examples of prediction charts : downpours, 21/03/2008

d7 : 2008/3/21 z0:0 +14h

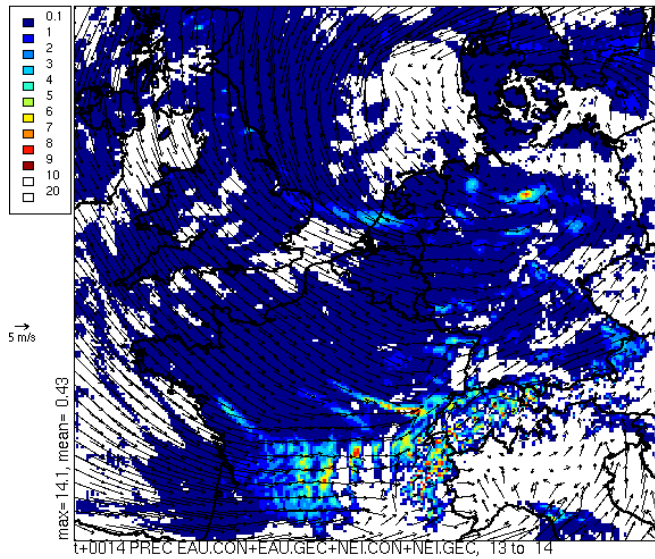

t7vi : 2008/3/21 z0:0 +14h

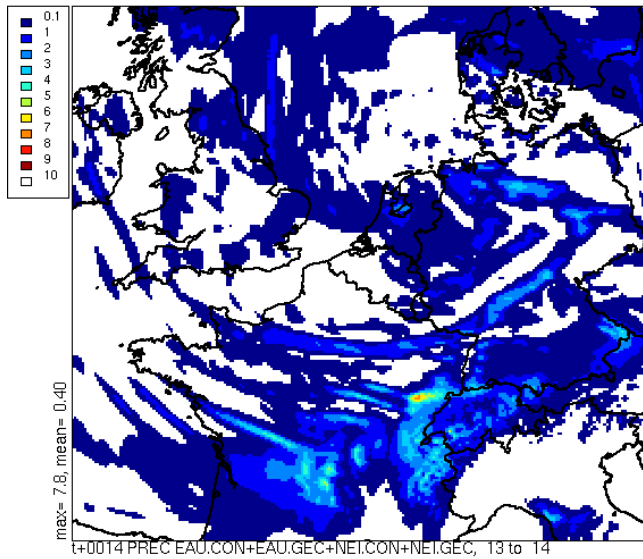

T4vi : 2008/3/21 z0:0 +14h

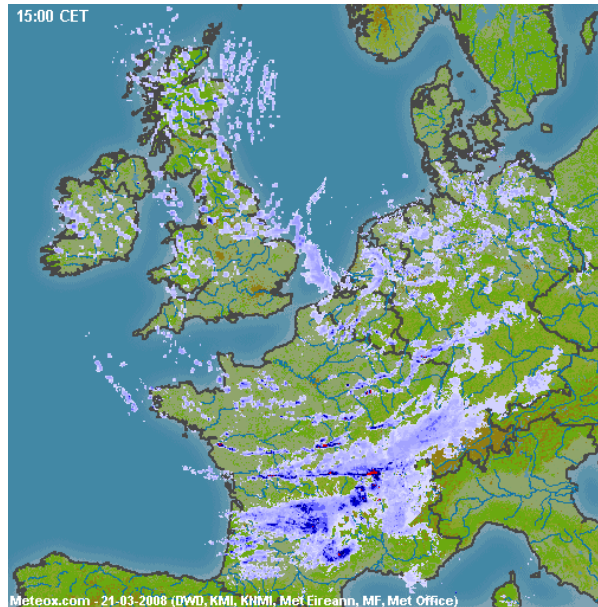
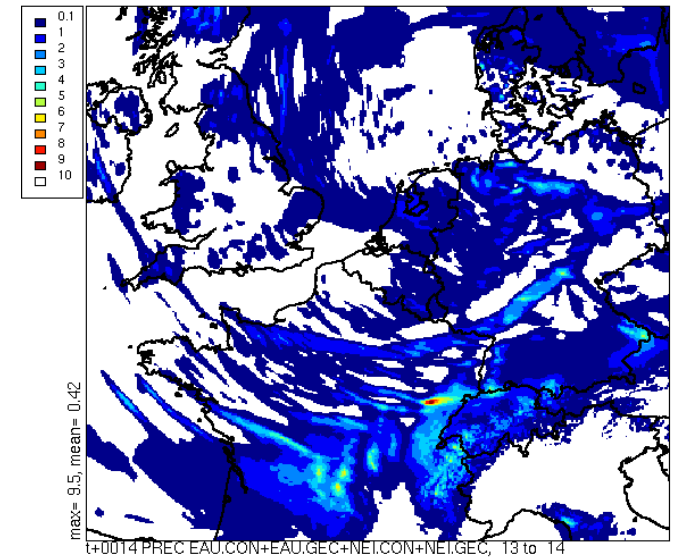

1h radar precipitation accumulation (mm) Starting at 21/03/2008 13 UT 12 /12 Radar Wideumont RMI - Belgium

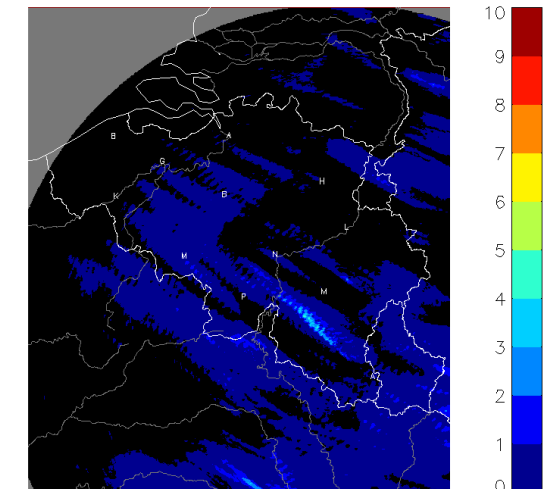



# Examples of prediction charts : downpours, 21/03/2008

d7 : 2008/3/21 z0:0 +15h

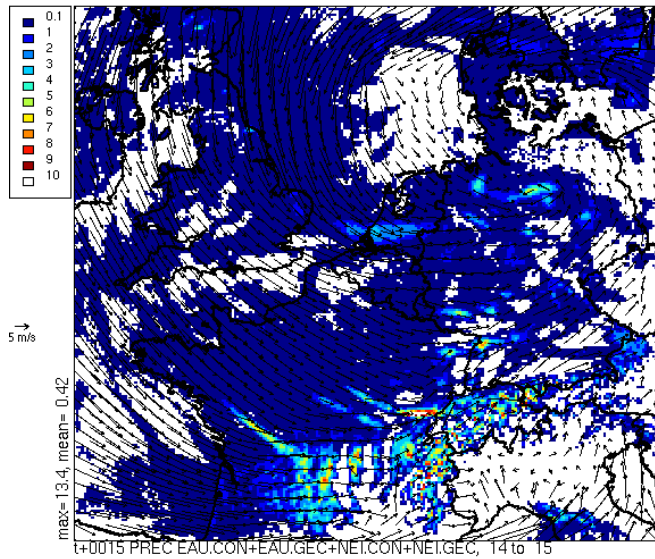

t7vl : 2008/3/21 z0:0 +15h

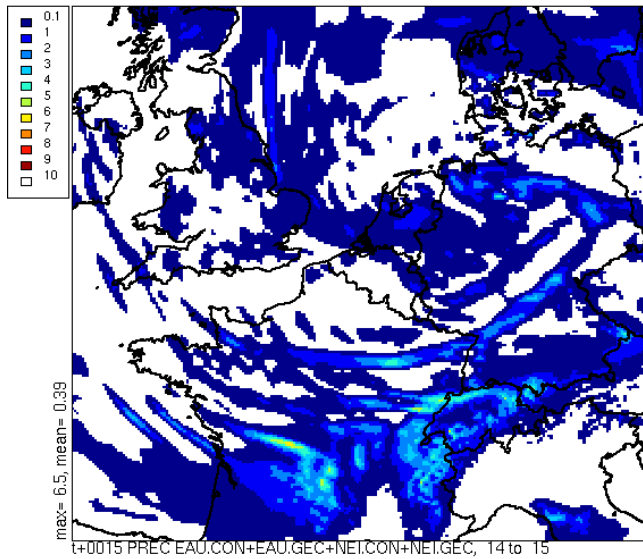

T4vl : 2008/3/21 z0:0 +15h

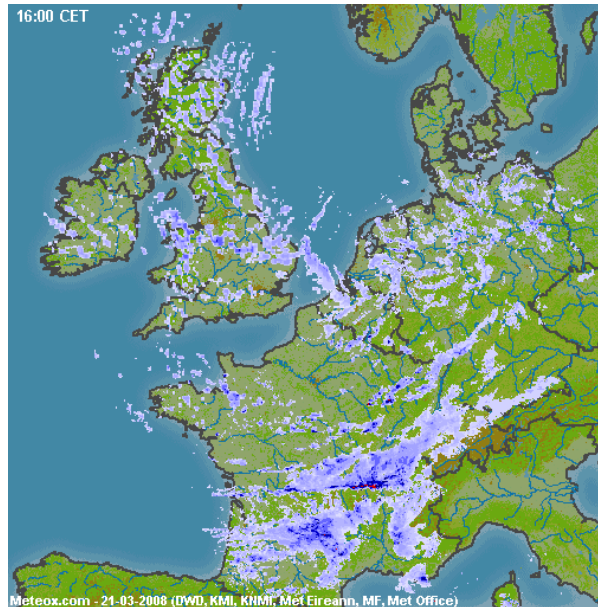
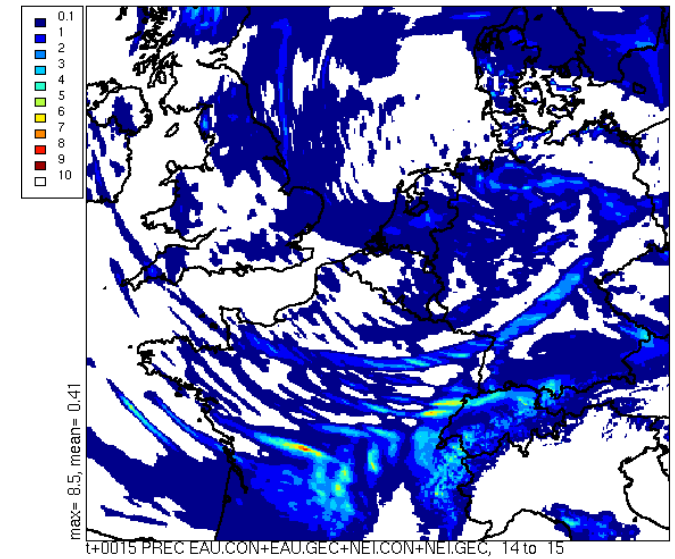

1h radar precipitation accumulation (mm) Starting at 21/03/2008 14 UT 12 /12

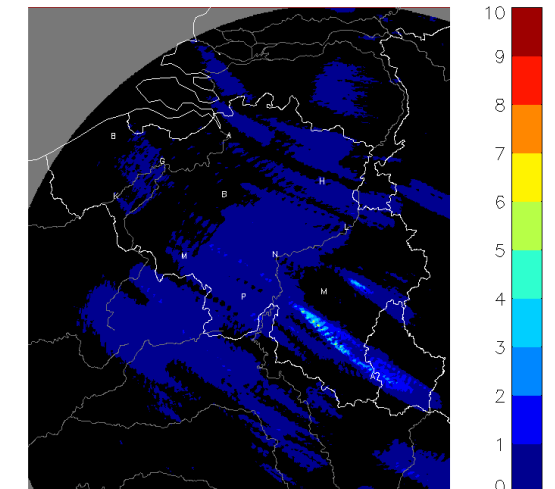

# Examples of prediction charts : downpours, 21/03/2008

d7 : 2008/3/21 z0:0 +16h

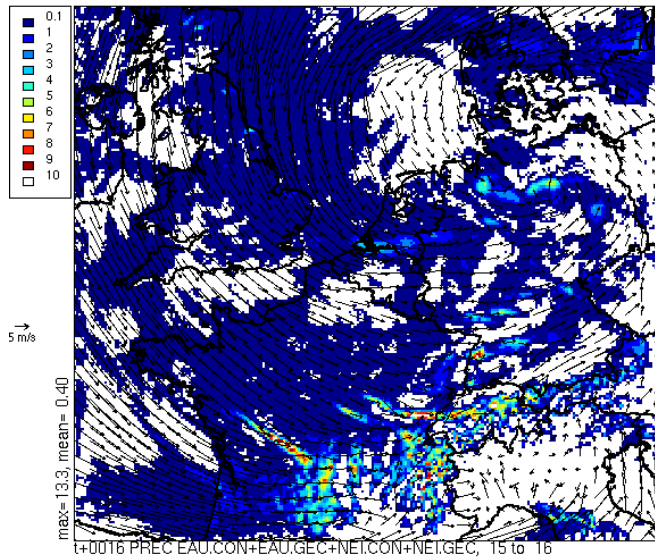

t7vl : 2008/3/21 z0:0 +16h

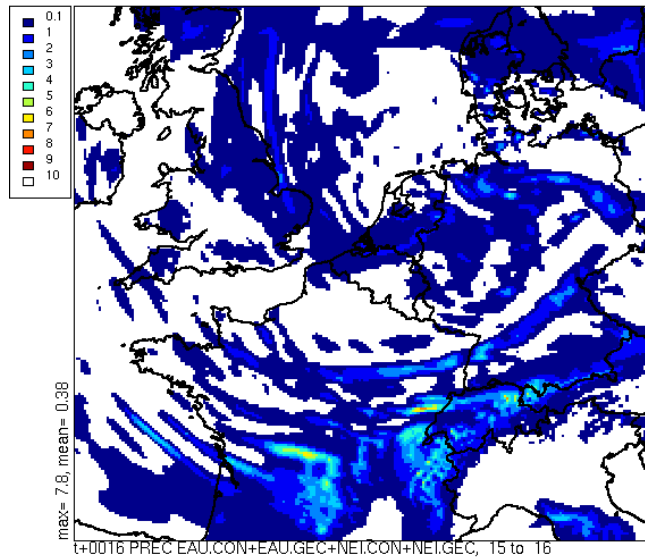

T4vl : 2008/3/21 z0:0 +16h

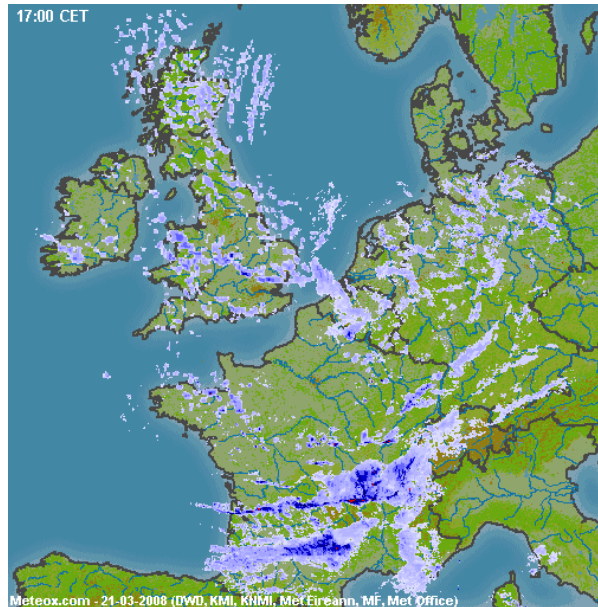
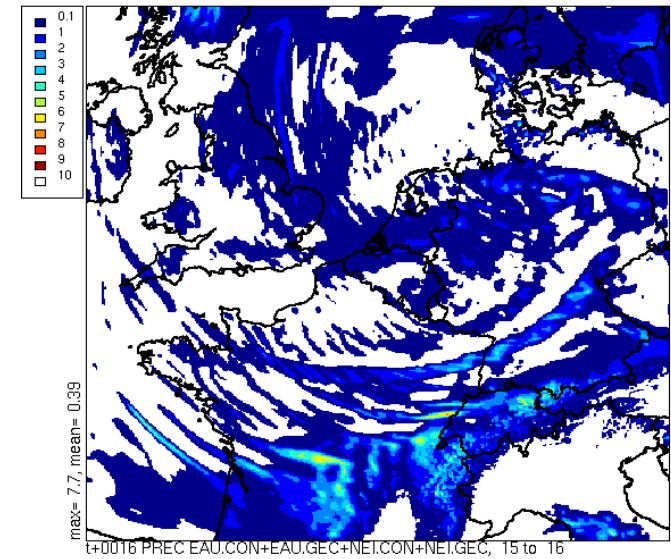

1h radar precipitation accumulation (mm) Starting at 21/03/2008 15 UT 12 /12 Radar Wideumont RMI - Belgium

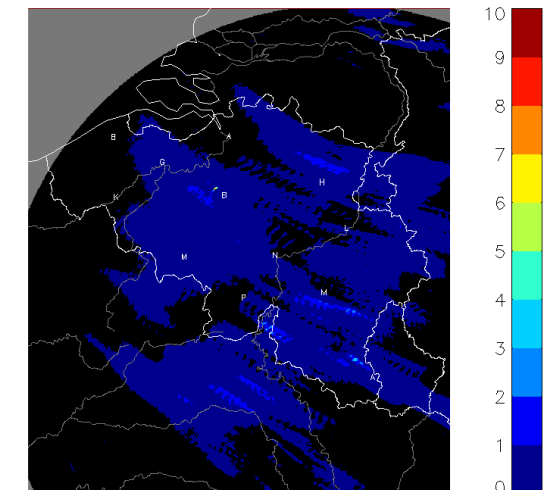



# Examples of prediction charts : downpours, 21/03/2008

d7 : 2008/3/21 z0:0 +17h

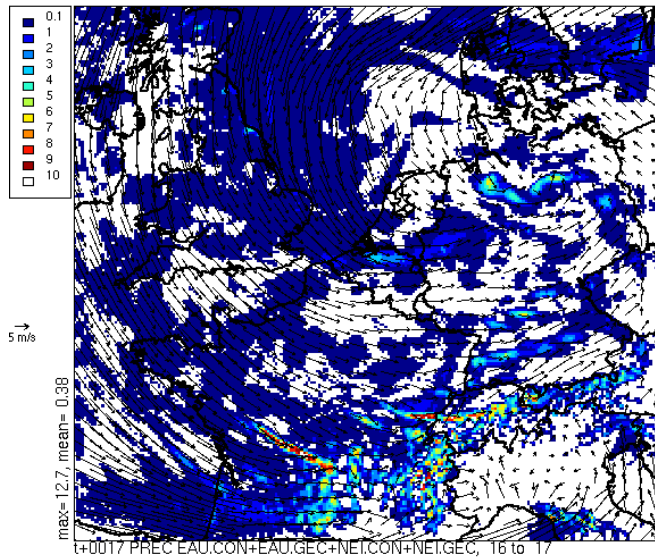

t7vl : 2008/3/21 z0:0 +17h

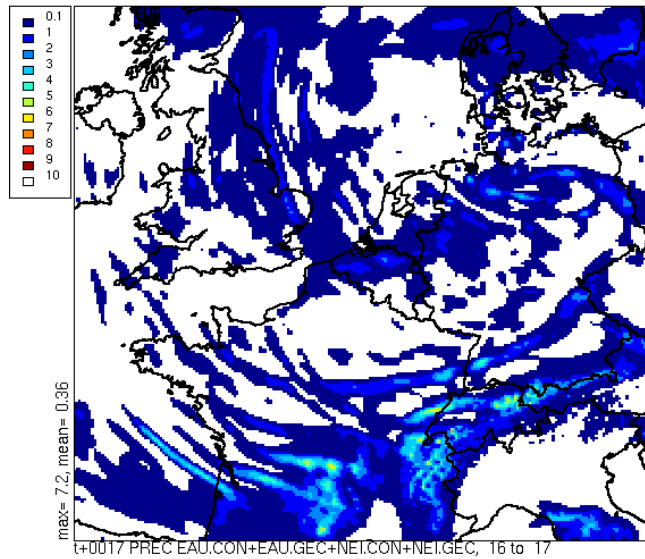

T4vl : 2008/3/21 z0:0 +17h

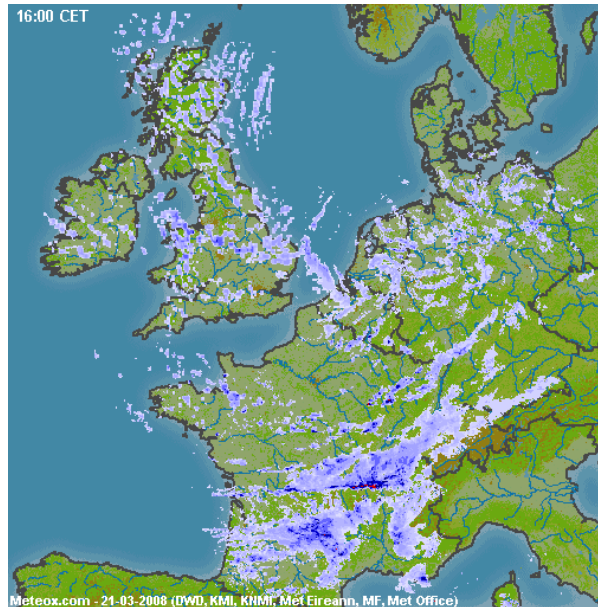
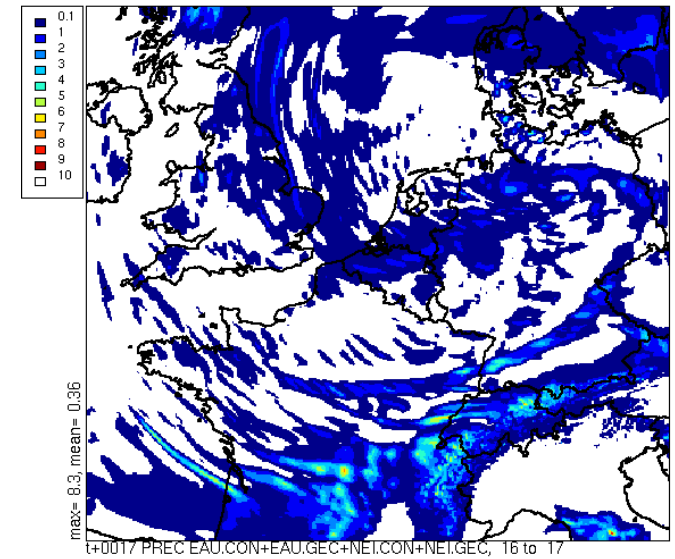

1h radar precipitation accumulation (mm)  
Starting at 21/03/2008 15 UT 12 /12  
RMI - Belgium

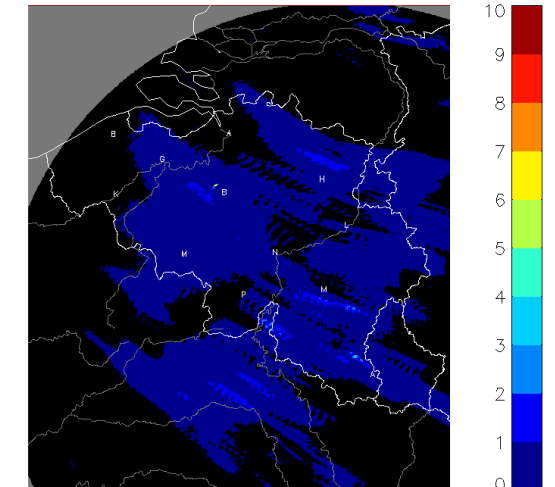

# Examples of prediction charts : squall lines 1/10/2006



# Examples of prediction charts : squall lines 1/10/2006

d7 : 2006/10/1 z0:0 +12h

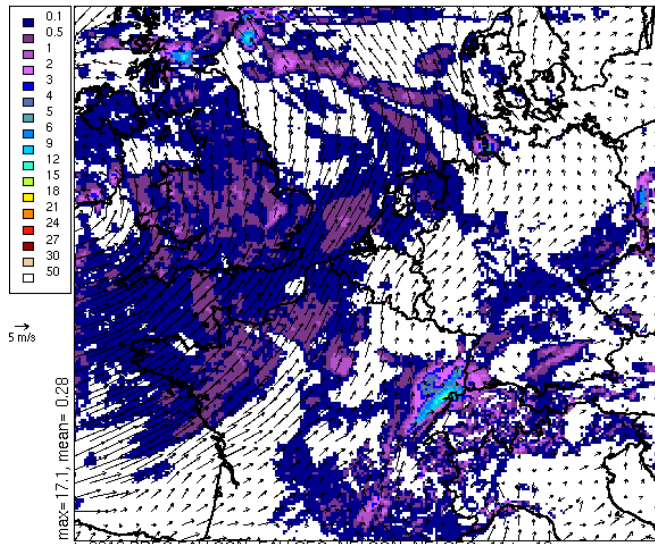

t7vl : 2006/10/1 z0:0 +12h

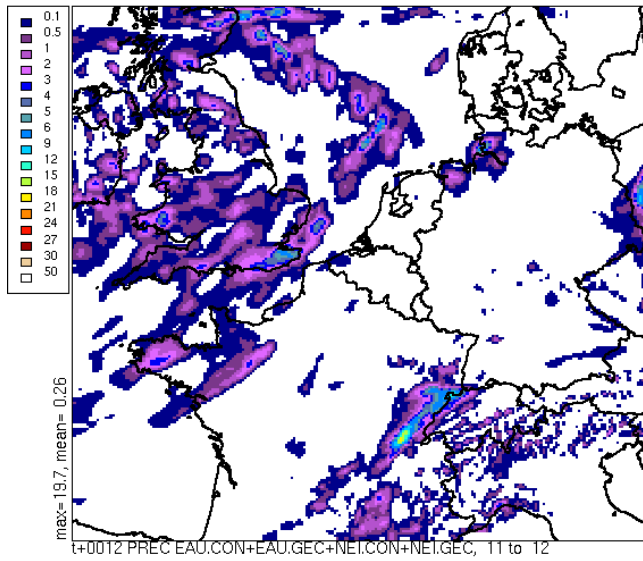

t4vl : 2006/10/1 z0:0 +12h

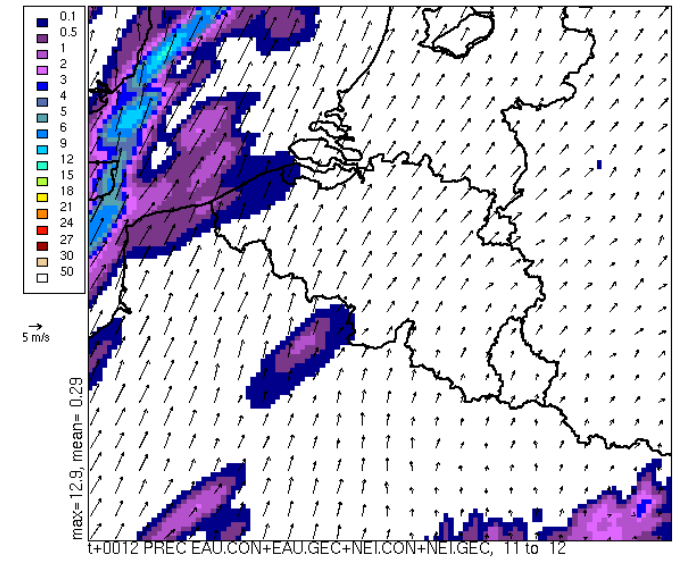

t2vl : 2006/10/1 z0:0 +12h

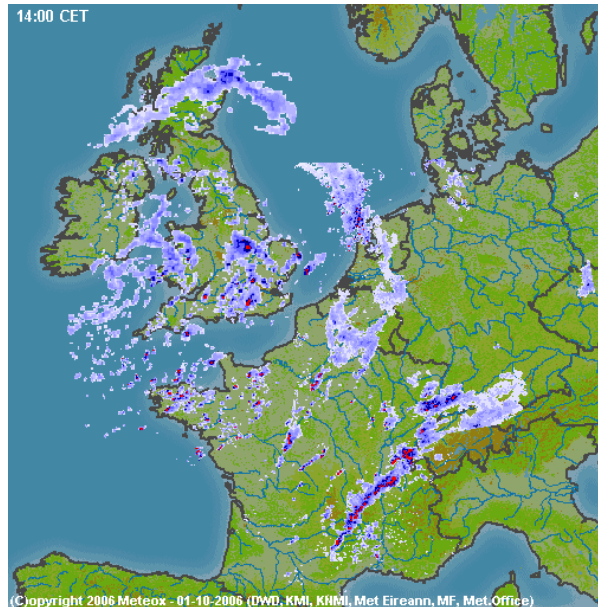
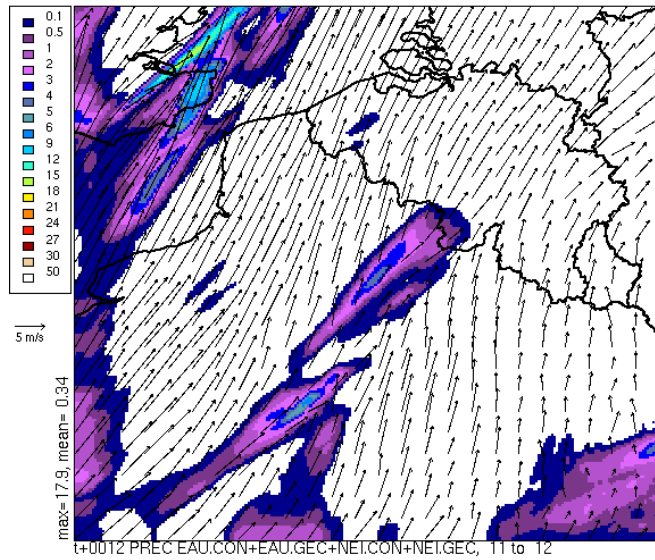

1h radar precipitation accumulation (mm) Starting at 01/10/2006 11 UT 12 /12 Radar Wideumont RMI - Belgium

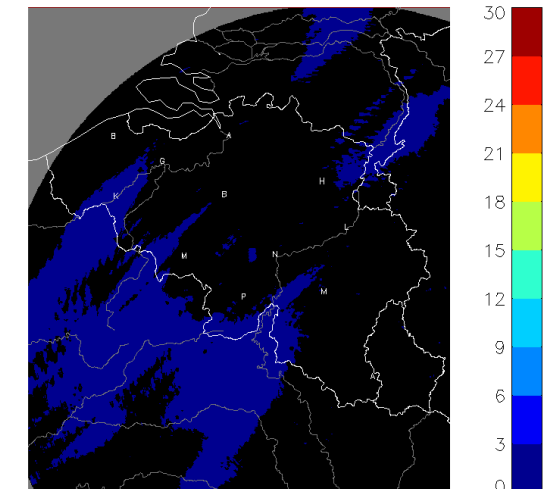

# Examples of prediction charts : squall lines 1/10/2006

d7 : 2006/10/1 z0:0 +13h

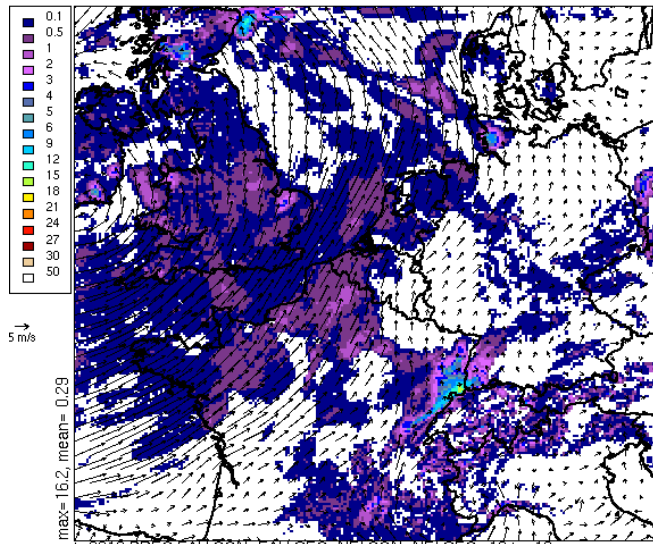

t7vl : 2006/10/1 z0:0 +13h

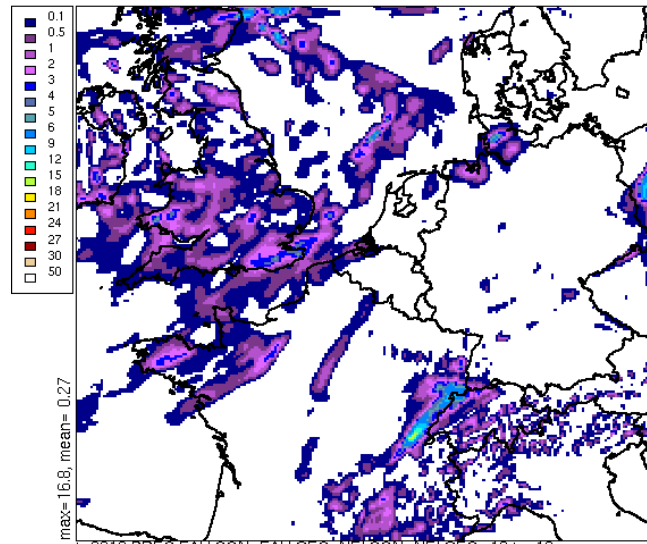

t4vl : 2006/10/1 z0:0 +13h

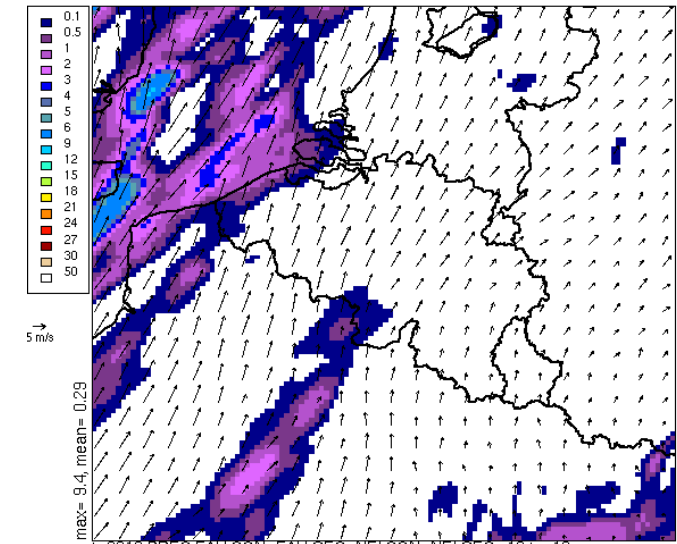

t2vl : 2006/10/1 z0:0 +13h

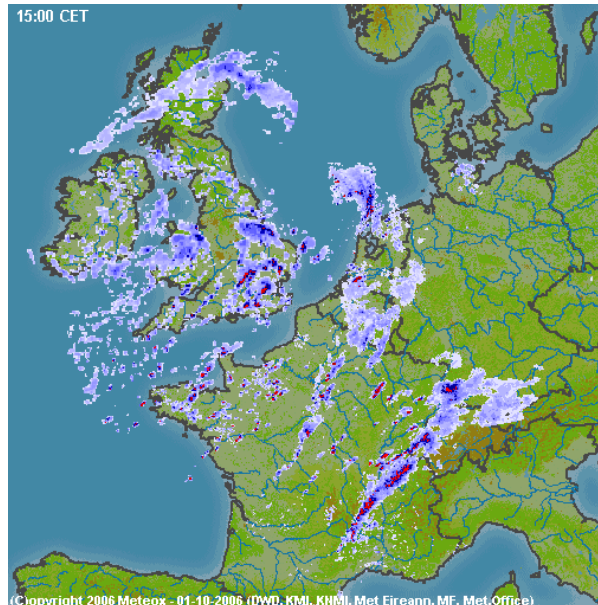
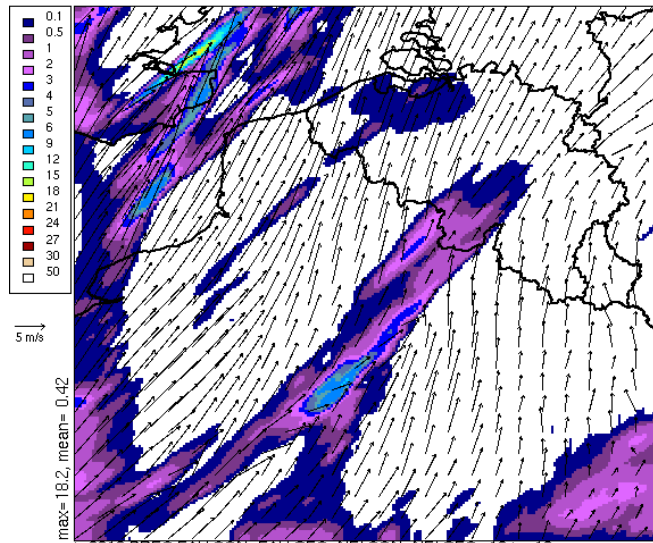

1h radar precipitation accumulation (mm) Starting at 01/10/2006 12 UT 12 /12 Radar Wideumont RMI - Belgium

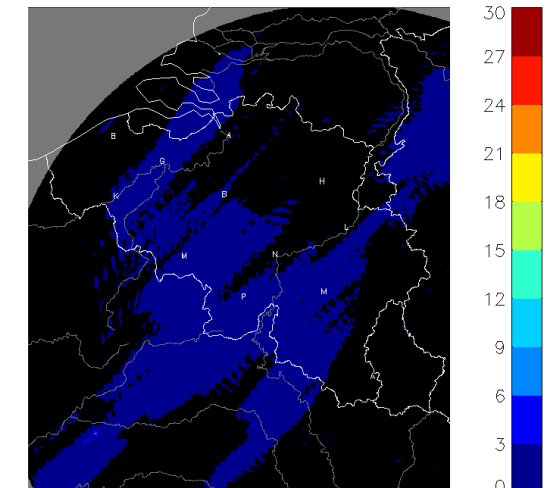



# Examples of prediction charts : squall lines 1/10/2006

d7 : 2006/10/1 z0:0 +14h

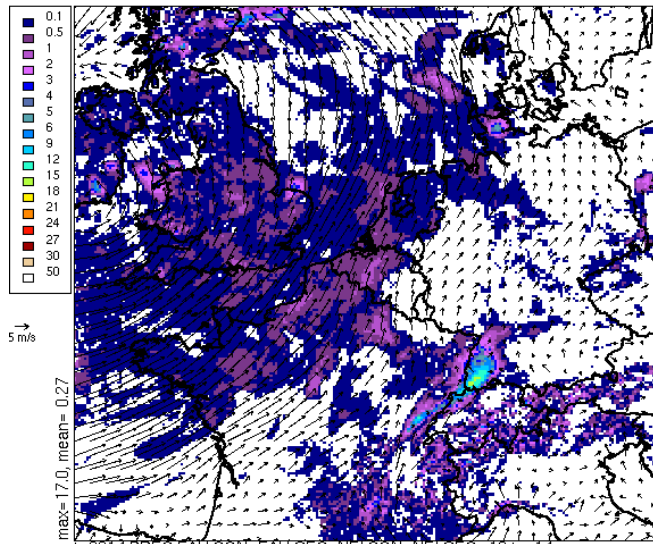

t7vl : 2006/10/1 z0:0 +14h

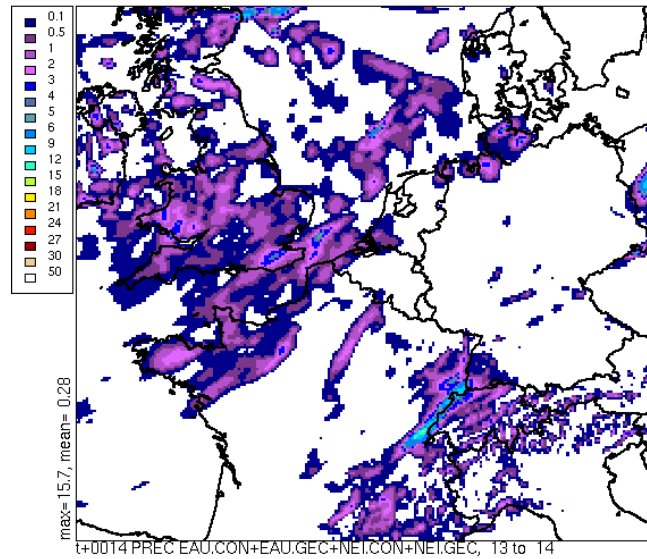

t4vl : 2006/10/1 z0:0 +14h

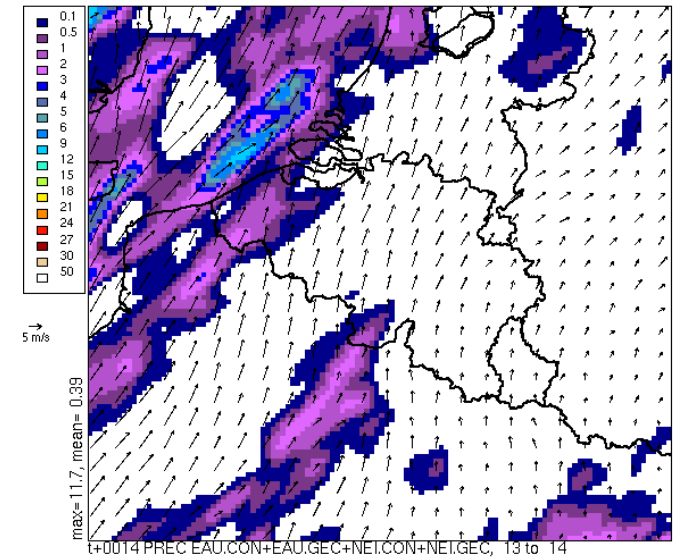

t2vl : 2006/10/1 z0:0 +14h

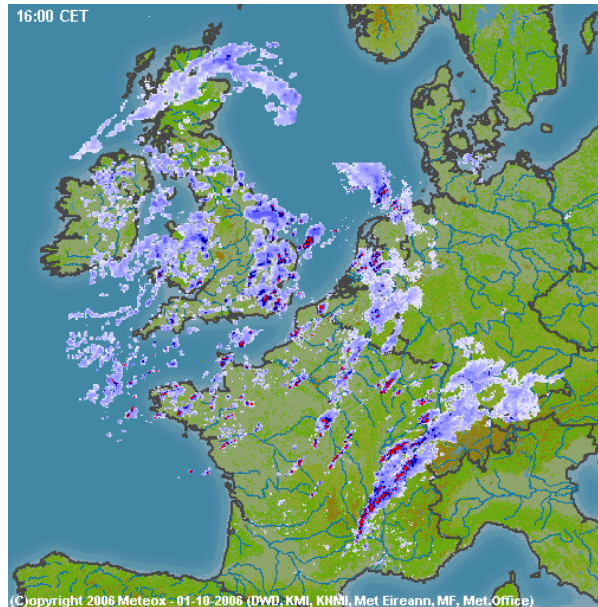
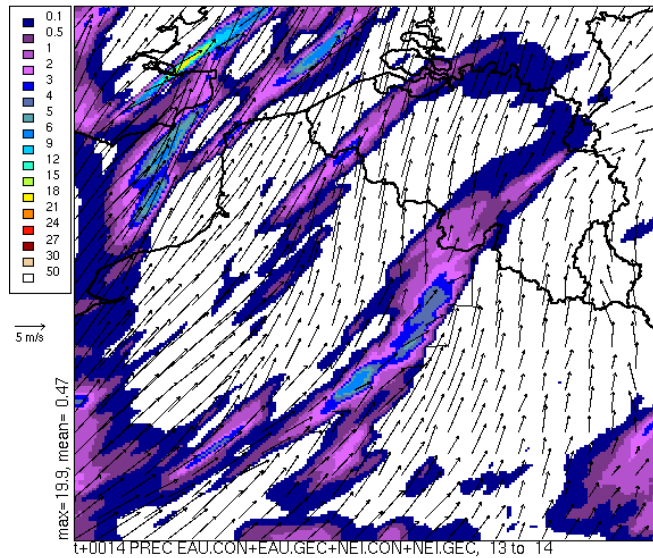

1h radar precipitation accumulation (mm) Starting at 01/10/2006 13 UT 12 /12 Radar Wideumont RMI - Belgium

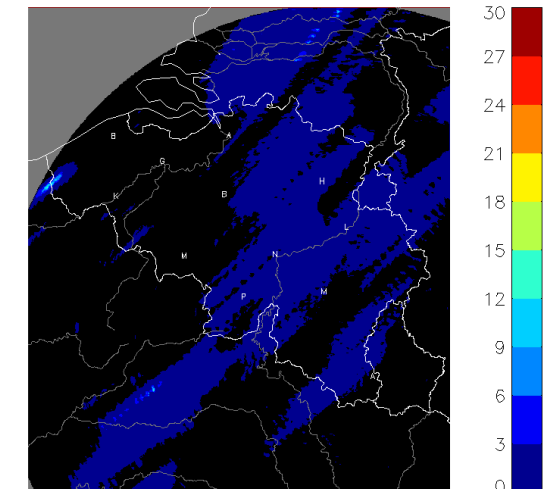

# Examples of prediction charts : squall lines 1/10/2006

d7 : 2006/10/1 z0:0 +15h

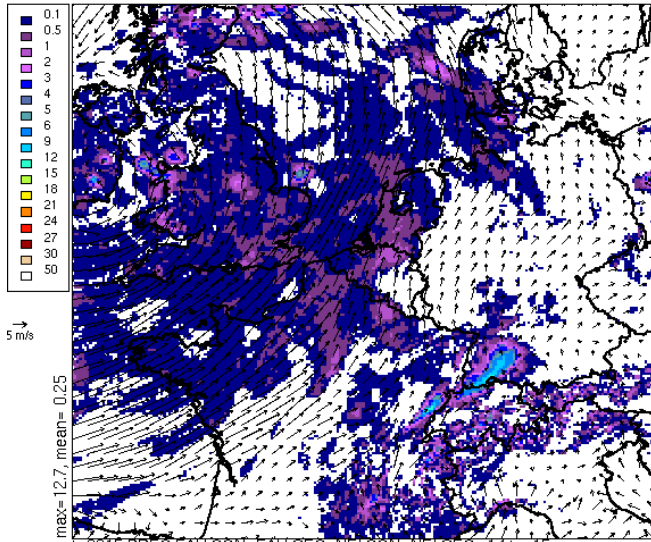

t7vl : 2006/10/1 z0:0 +15h

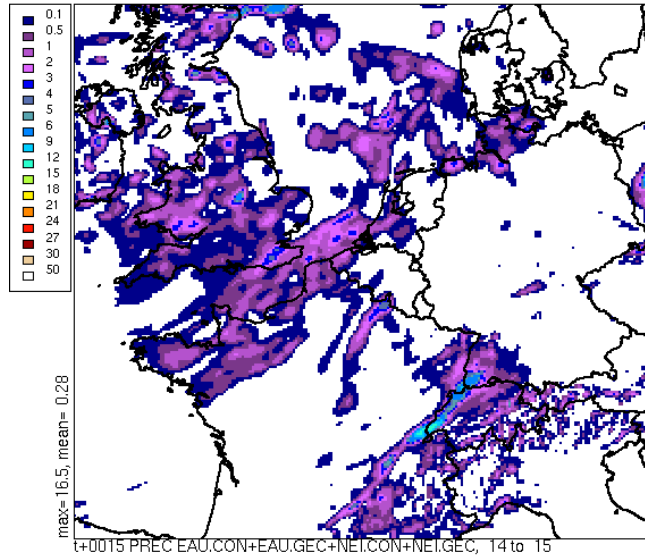

t4vl : 2006/10/1 z0:0 +15h

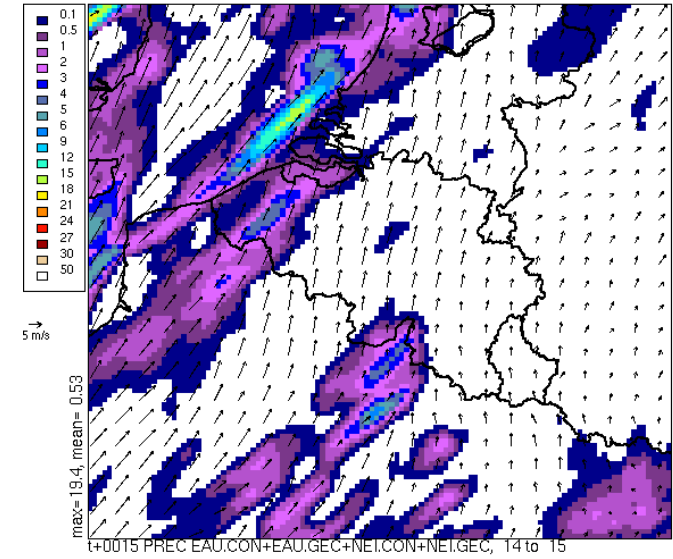

t2vl : 2006/10/1 z0:0 +15h

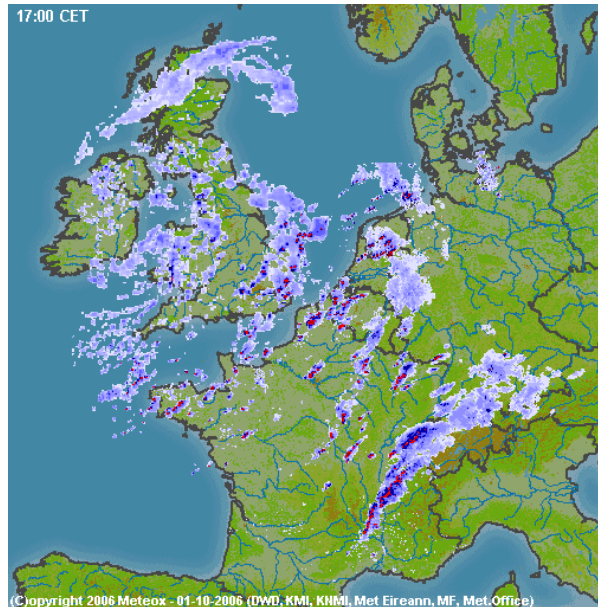
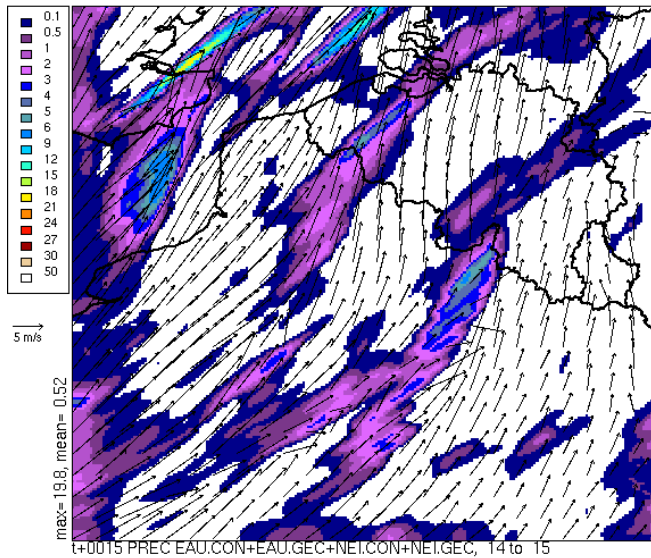

1h radar precipitation accumulation (mm) Starting at 01/10/2006 14 UT 12 /12 Radar Wideumont RMI - Belgium

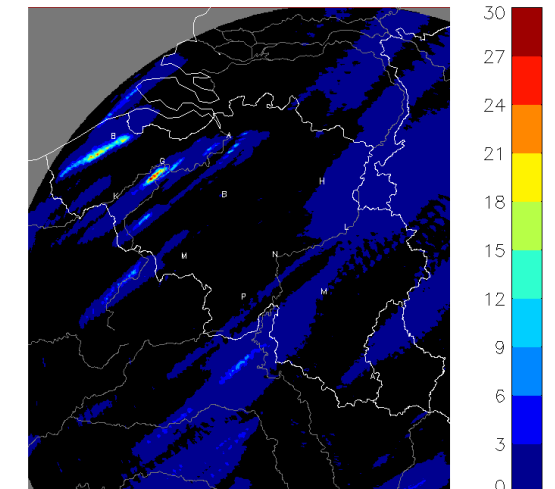



# Examples of prediction charts : squall lines 1/10/2006

d7 : 2006/10/1 z0:0 +16h

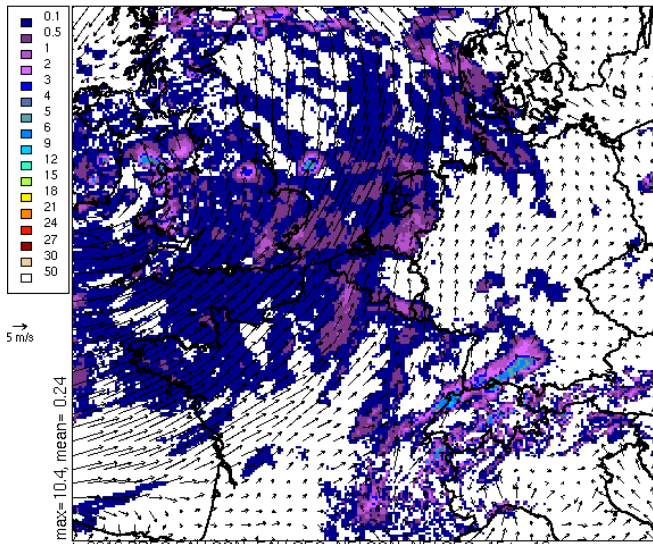

t7vl : 2006/10/1 z0:0 +16h

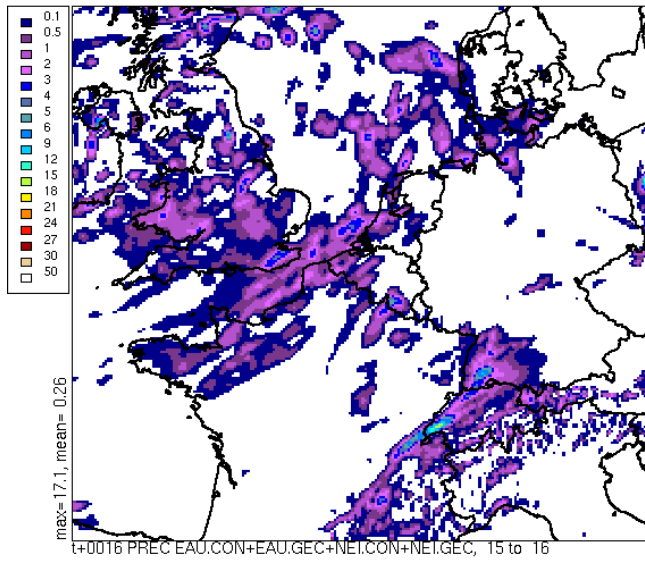

t4vl : 2006/10/1 z0:0 +16h

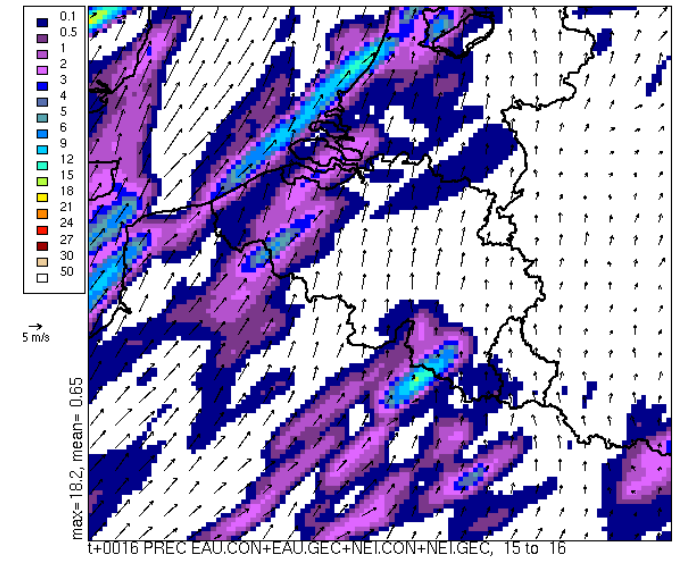

t2vl : 2006/10/1 z0:0 +16h

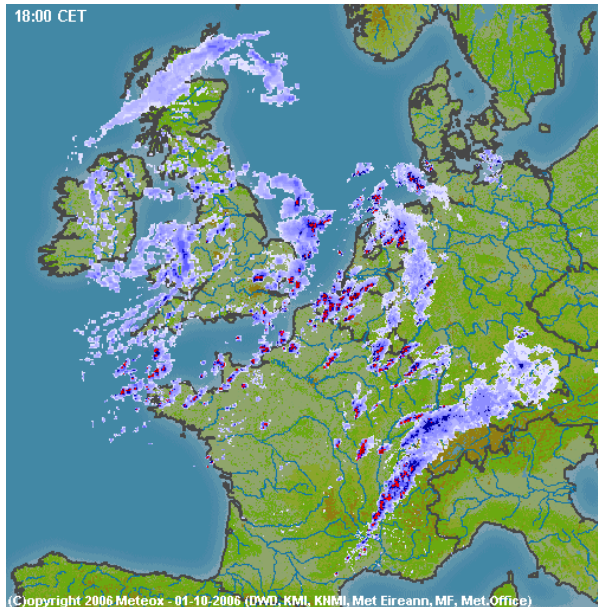
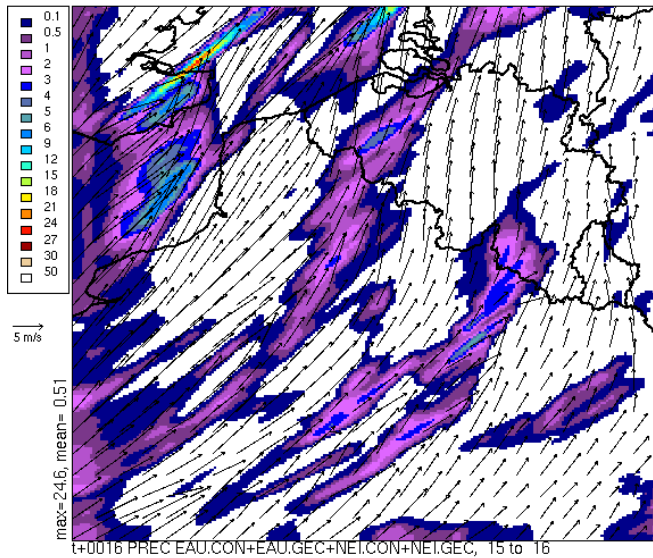

# Examples of prediction charts : squall lines 1/10/2006

d7 : 2006/10/1 z0:0 +17h

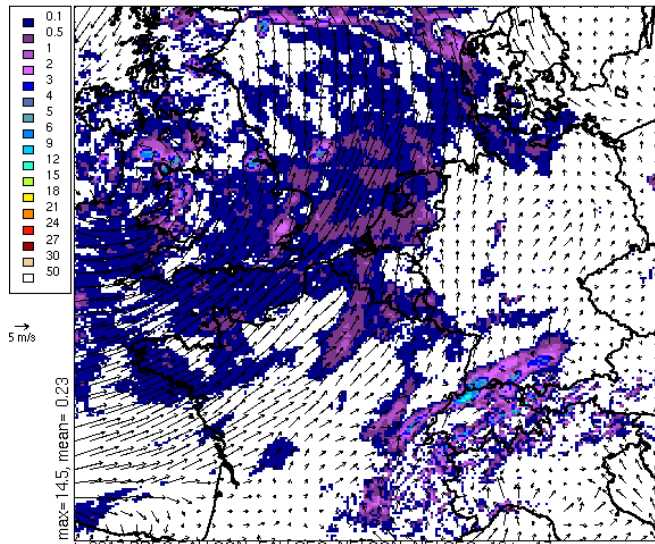

t7vl : 2006/10/1 z0:0 +17h

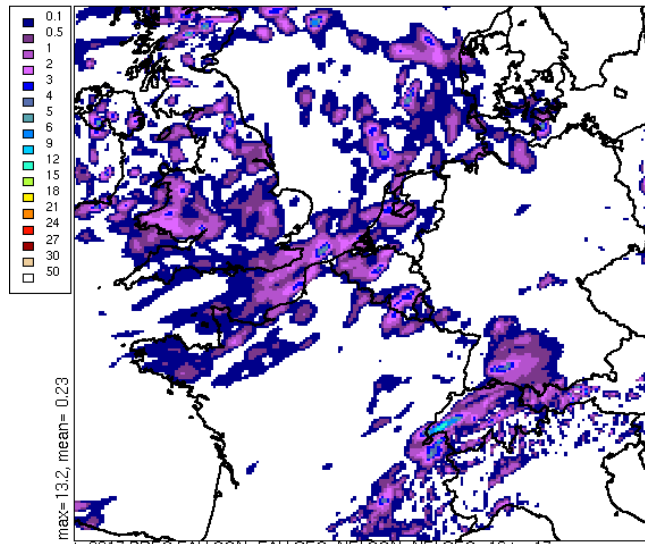

t4vl : 2006/10/1 z0:0 +17h

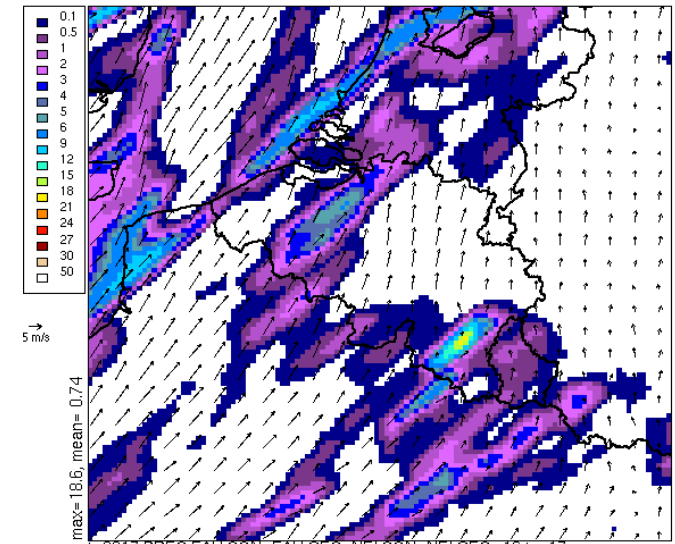

t2vl : 2006/10/1 z0:0 +17h

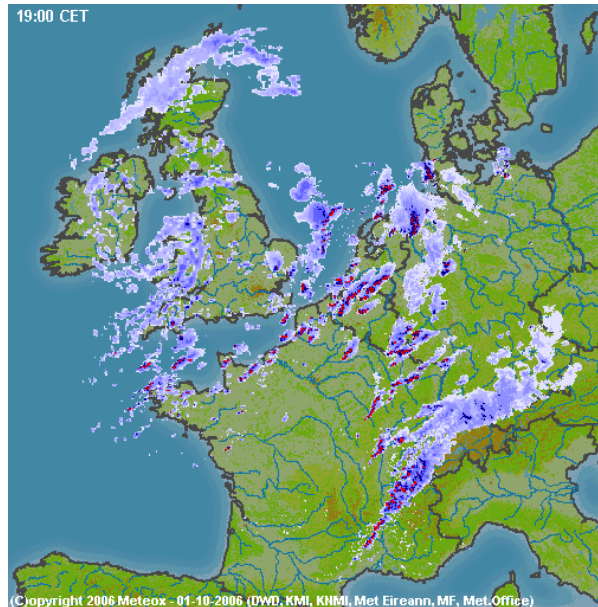
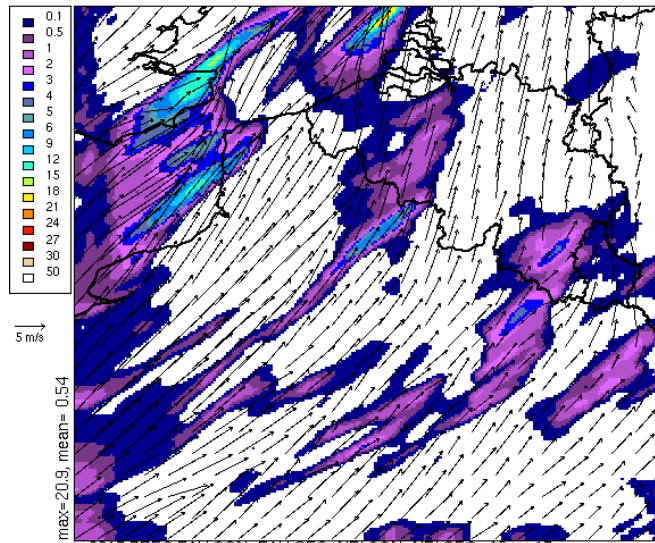

1h radar precipitation accumulation (mm) Starting at 01/10/2006 16 UT 12 /12 Radar Wideumont RMI - Belgium

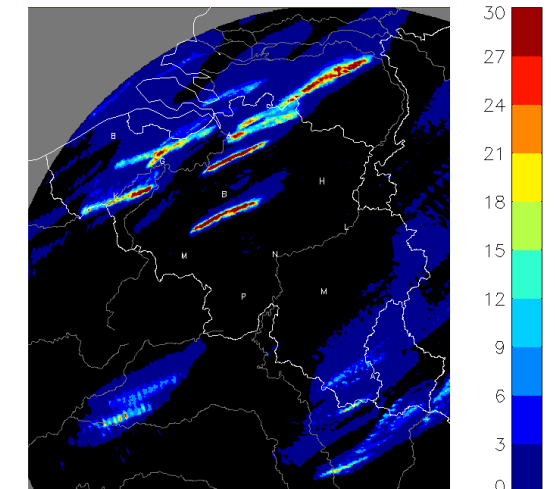



# Examples of prediction charts : squall lines 1/10/2006

d7 : 2006/10/1 z0:0 +18h

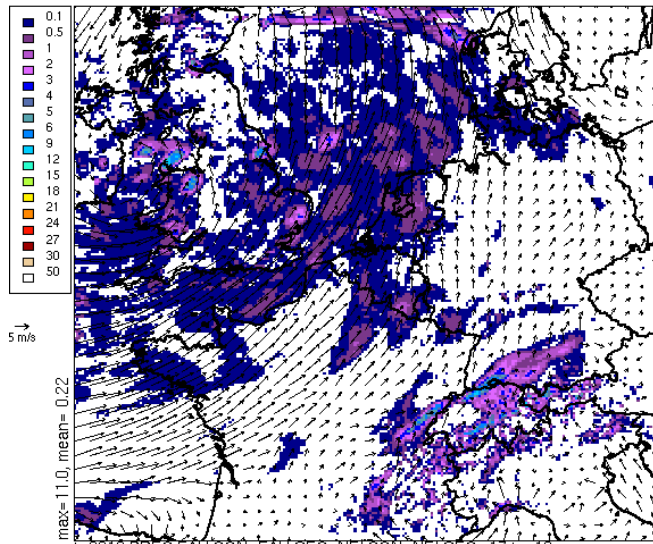

t7vl : 2006/10/1 z0:0 +18h

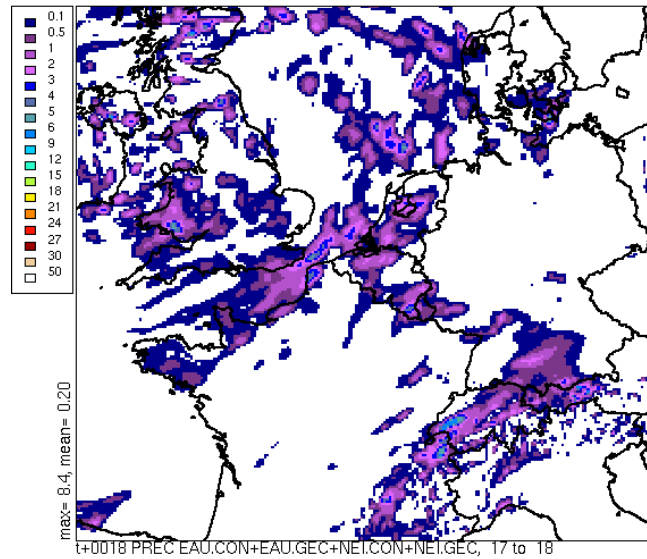

t4vl : 2006/10/1 z0:0 +18h

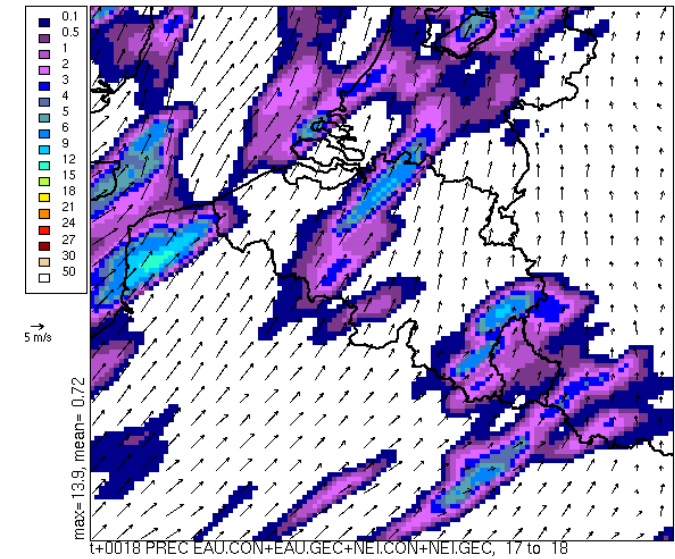

t2vl : 2006/10/1 z0:0 +18h

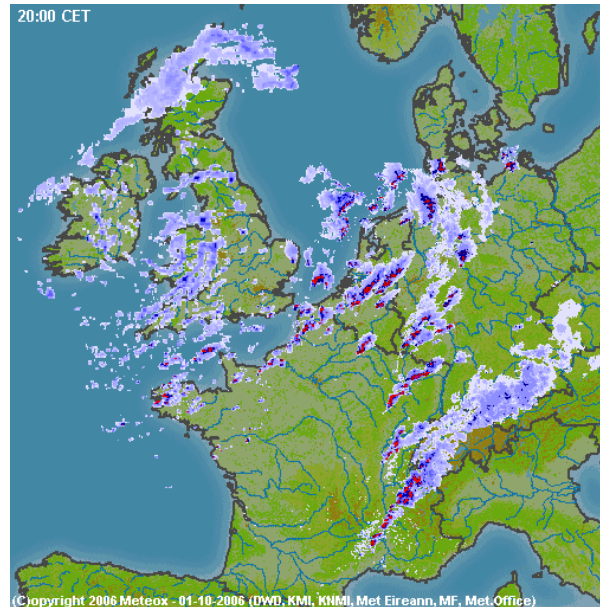
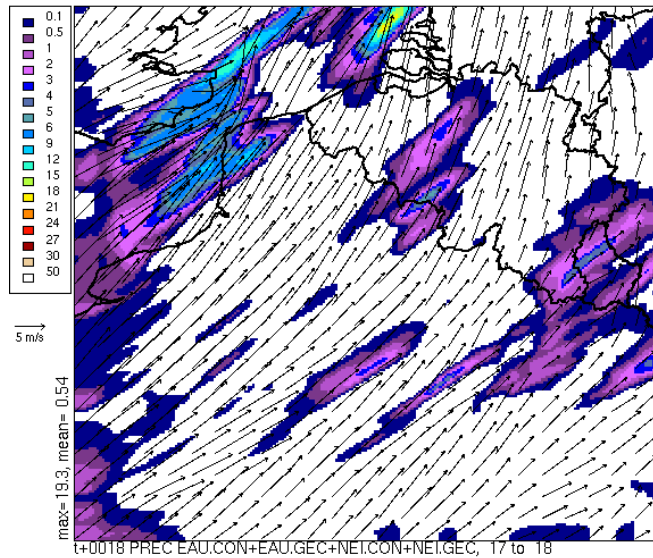

1h radar precipitation accumulation (mm) Starting at 01/10/2006 17 UT 12 /12 Radar Wideumont RMI - Belgium

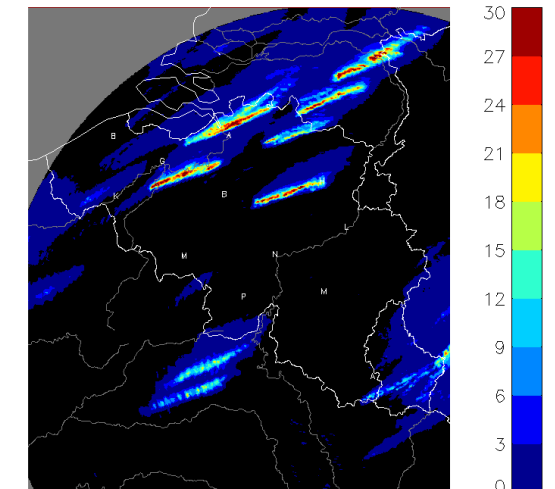

# Examples of prediction charts : squall lines 1/10/2006

d7 : 2006/10/1 z0:0 +19h

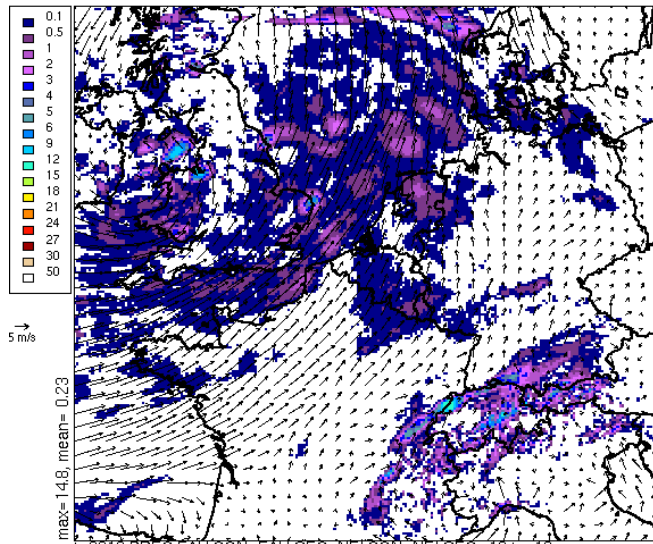

t7vl : 2006/10/1 z0:0 +19h

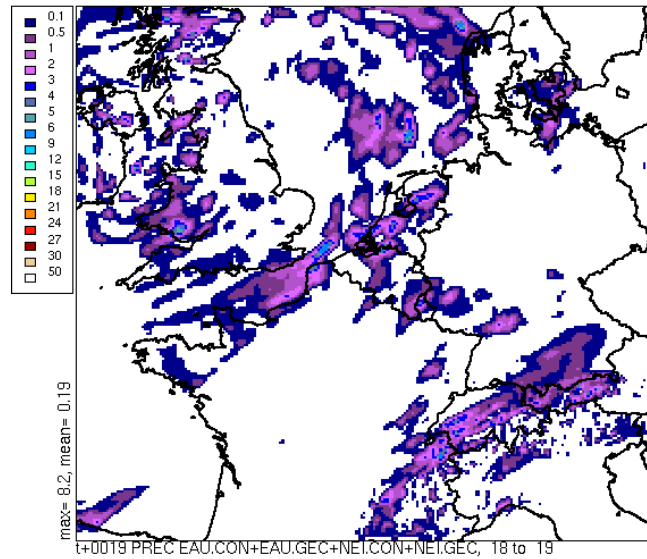

t4vl : 2006/10/1 z0:0 +19h

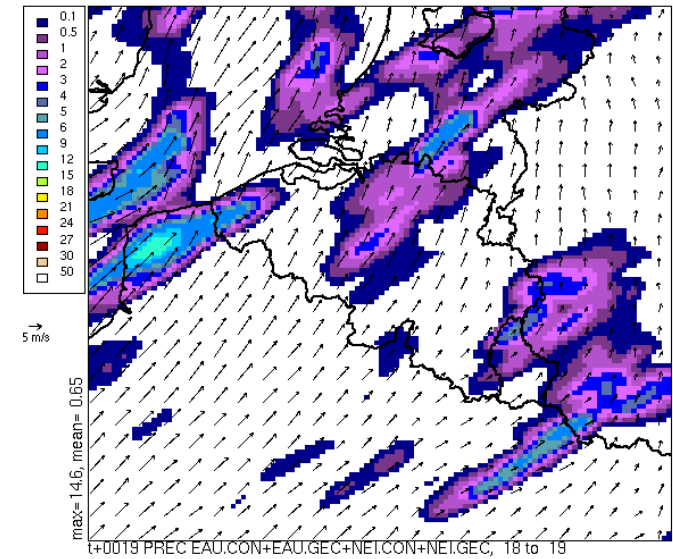

t2vl : 2006/10/1 z0:0 +19h

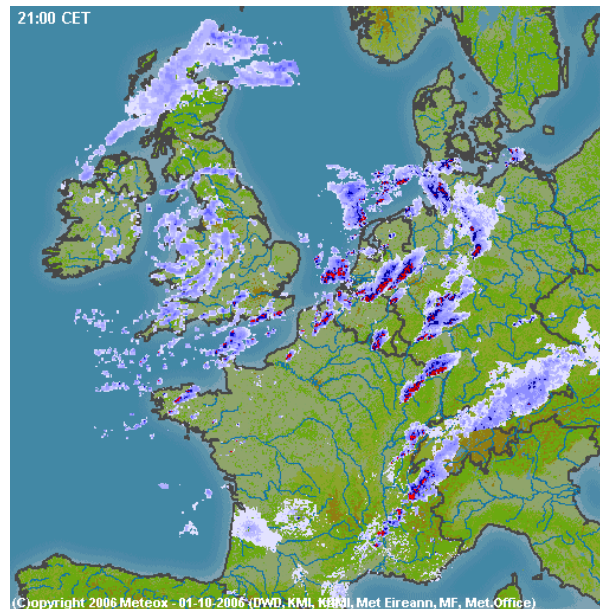
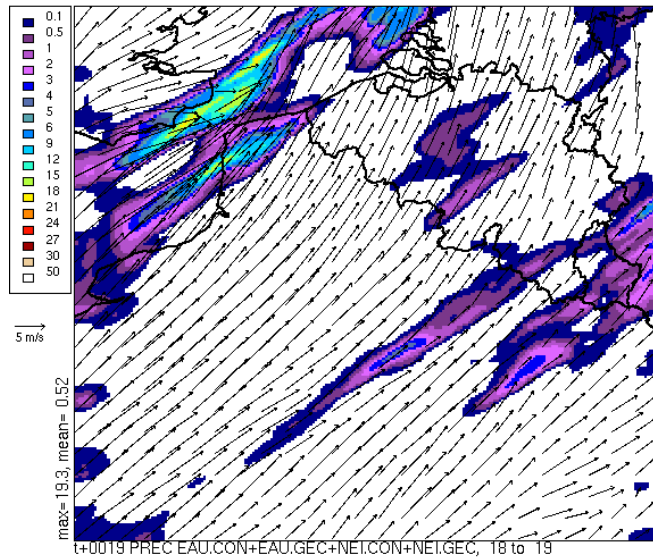

1h radar precipitation accumulation (mm) Radar Wideumont  
Starting at 01/10/2006 18 UT 12 /12 RMI - Belgium

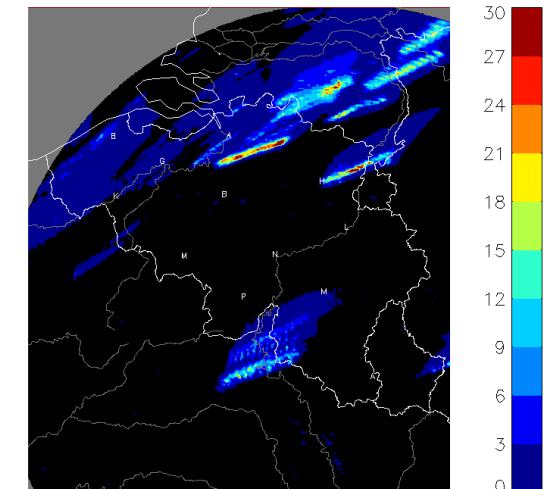



# Examples of prediction charts : squall lines 1/10/2006

d7 : 2006/10/1 z0:0 +20h

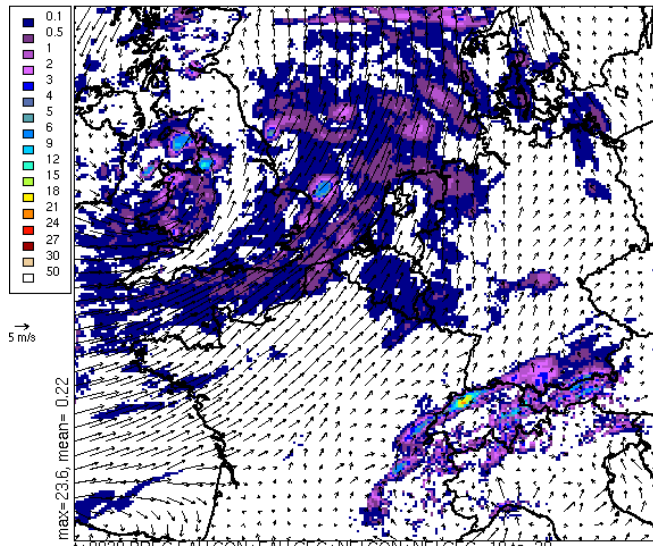

t7vl : 2006/10/1 z0:0 +20h

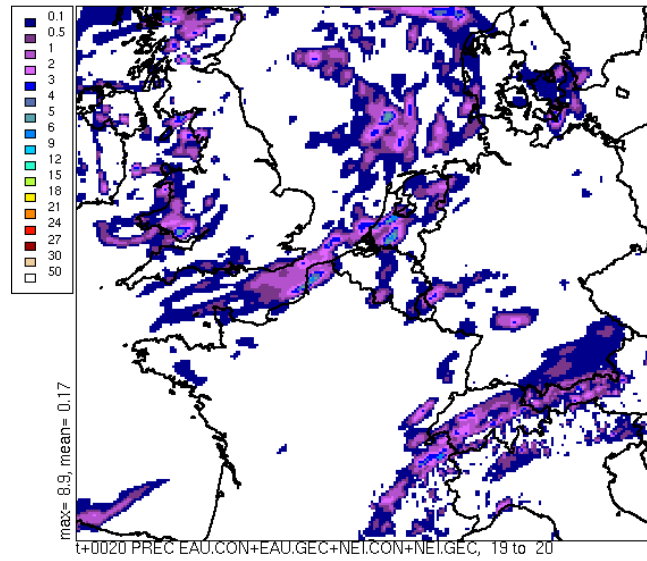

t4vl : 2006/10/1 z0:0 +20h

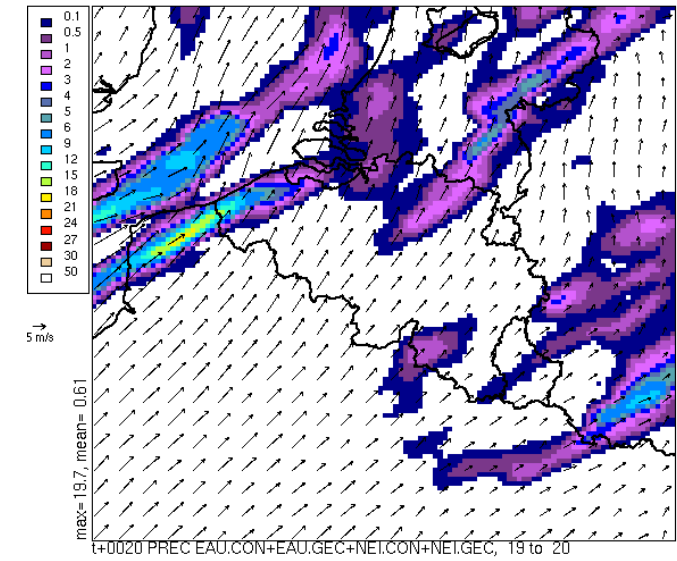

t2vl : 2006/10/1 z0:0 +20h

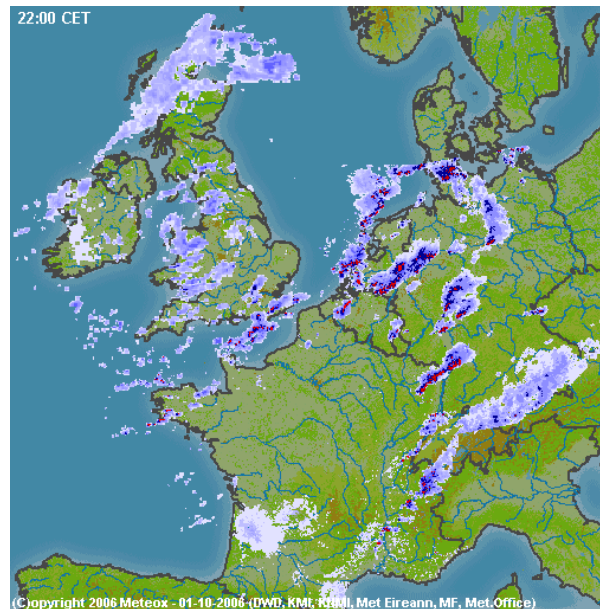
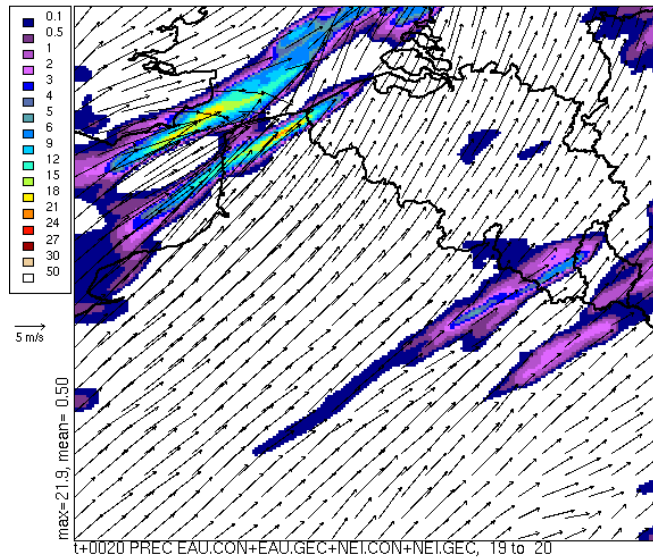

1h radar precipitation accumulation (mm) Starting at 01/10/2006 19 UT 12 /12

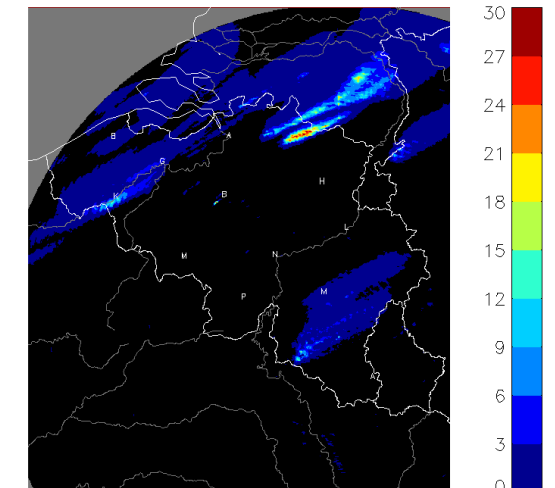

# Examples of prediction charts : squall lines 1/10/2006

d7 : 2006/10/1 z0:0 +21h

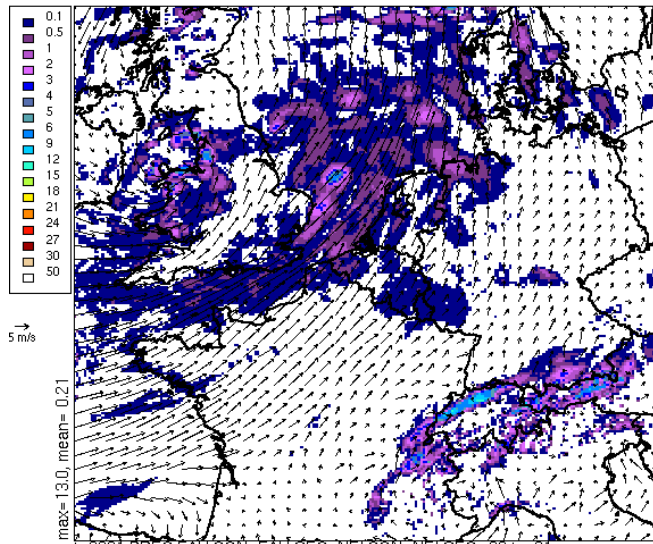

t7vl : 2006/10/1 z0:0 +21h

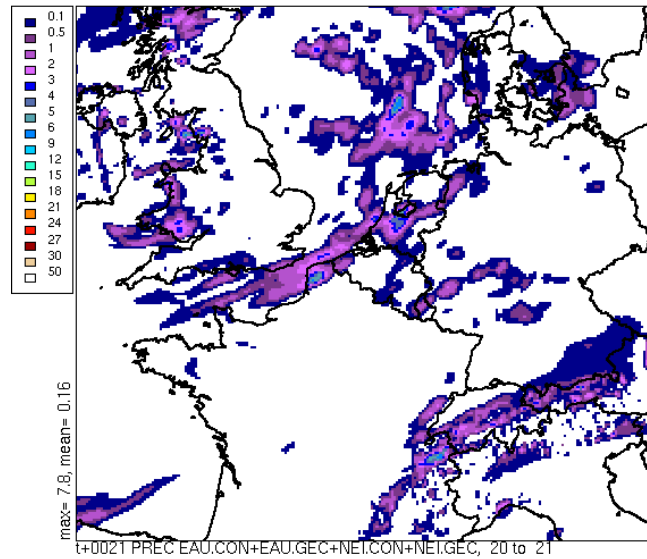

t4vl : 2006/10/1 z0:0 +21h

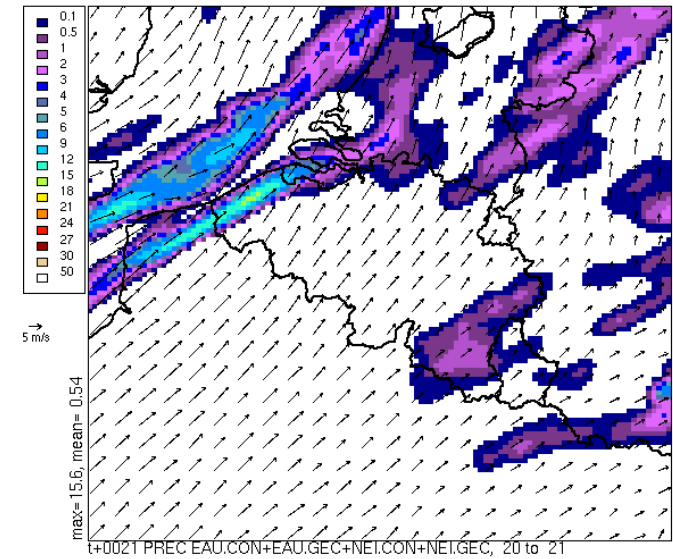

t2vl : 2006/10/1 z0:0 +21h

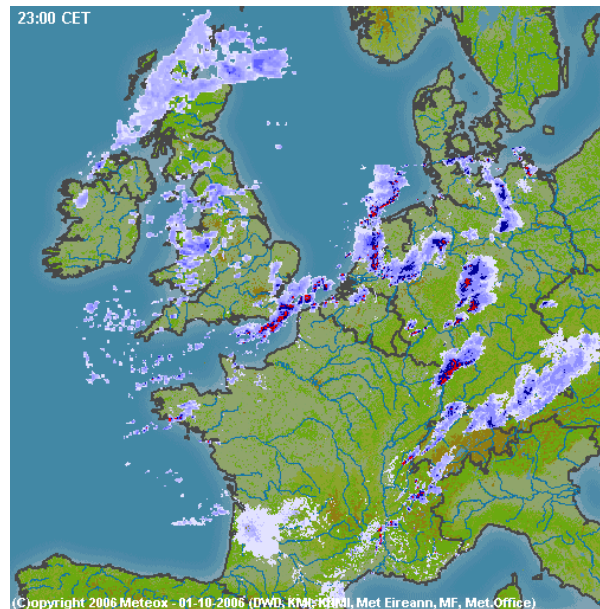
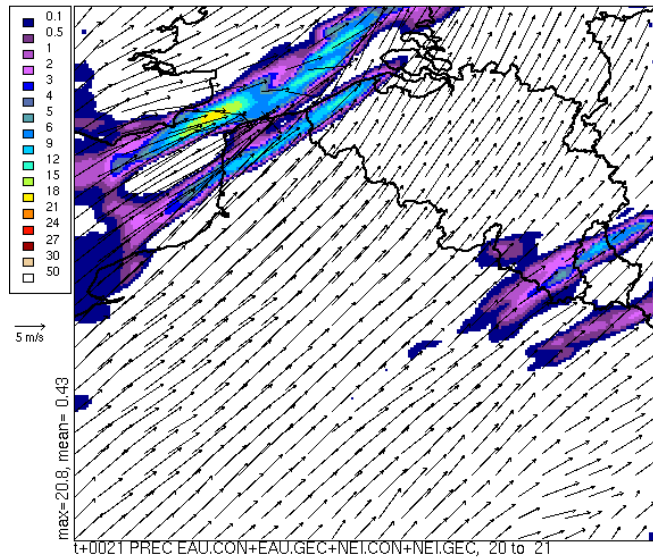

1h radar precipitation accumulation (mm) Starting at 01/10/2006 20 UT 11 /12 Radar Wideumont RMI - Belgium

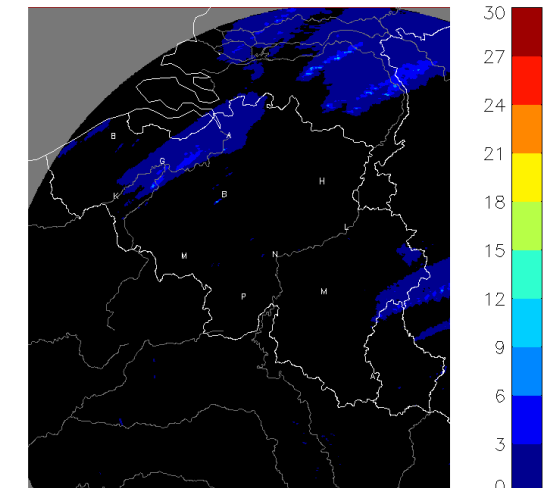

# Further work

- Systematic multi-scale study :
  - multi-scale tuning ;
  - skill scores and benefits of 4-km runs ;
  - non-hydrostatic aspects.

# Further work

- Systematic multi-scale study :
  - multi-scale tuning ;
  - skill scores and benefits of 4-km runs ;
  - non-hydrostatic aspects.
  
- Further assessment of detrainment/protected area behaviour

# Further work

- Systematic multi-scale study :
  - multi-scale tuning ;
  - skill scores and benefits of 4-km runs ;
  - non-hydrostatic aspects.
  
- Further assessment of detrainment/protected area behaviour
  
- Entrainment :
  - prognostic mixing
  - top vs lateral entrainment
  - Cloud top instability

# Further work

- Systematic multi-scale study :
  - multi-scale tuning ;
  - skill scores and benefits of 4-km runs ;
  - non-hydrostatic aspects.
- Further assessment of detrainment/protected area behaviour
- Entrainment :
  - prognostic mixing
  - top vs lateral entrainment
  - Cloud top instability
- Triggering of deep convection

# Further work

- Systematic multi-scale study :
  - multi-scale tuning ;
  - skill scores and benefits of 4-km runs ;
  - non-hydrostatic aspects.
- Further assessment of detrainment/protected area behaviour
- Entrainment :
  - prognostic mixing
  - top vs lateral entrainment
  - Cloud top instability
- Triggering of deep convection
- Use of SURFEX